

# Elecraft K2 Schematics

Compiled by Sverre Holm, LA3ZA, from manual pages of [www.elecraft.com](http://www.elecraft.com)

Rev 1.0 - 18 February 2005

## Contents:

1.	K2 Block Diagram Rev D	3
2.	K2 Schematic Key Rev D	4
3.	K2 Front Panel Board Rev C	5
4.	K2 Control Board Rev F	6
5.	K2 RF Board Rev F	7
6.	K2 Manual Errata Rev F-2	11
7.	KPA100 Schematics Rev G	12
8.	KPA100 Errata Rev C-3	14
9.	KSB2 Schematics Rev F	15
10.	SSB Bandwidth Modification Rev A	16
11.	K160RX Schematics Rev A	18
12.	KNB2 Schematics Rev D	19
13.	KBT2 Schematics	20
14.	KAT2 Schematics Rev F	21
15.	KAT100 Schematics Rev B	23
16.	KIO2 Schematics Rev E	26
17.	KDSP2 Schematics Rev C2	27
18.	KAF2 Schematics Rev A	29
19.	K60XV Schematics Rev B	30
20.	K60XV Errata Rev A-3	31

These schematics may be used for personal non-commercial use only.  
(c) 1999-2005 Elecraft, Inc



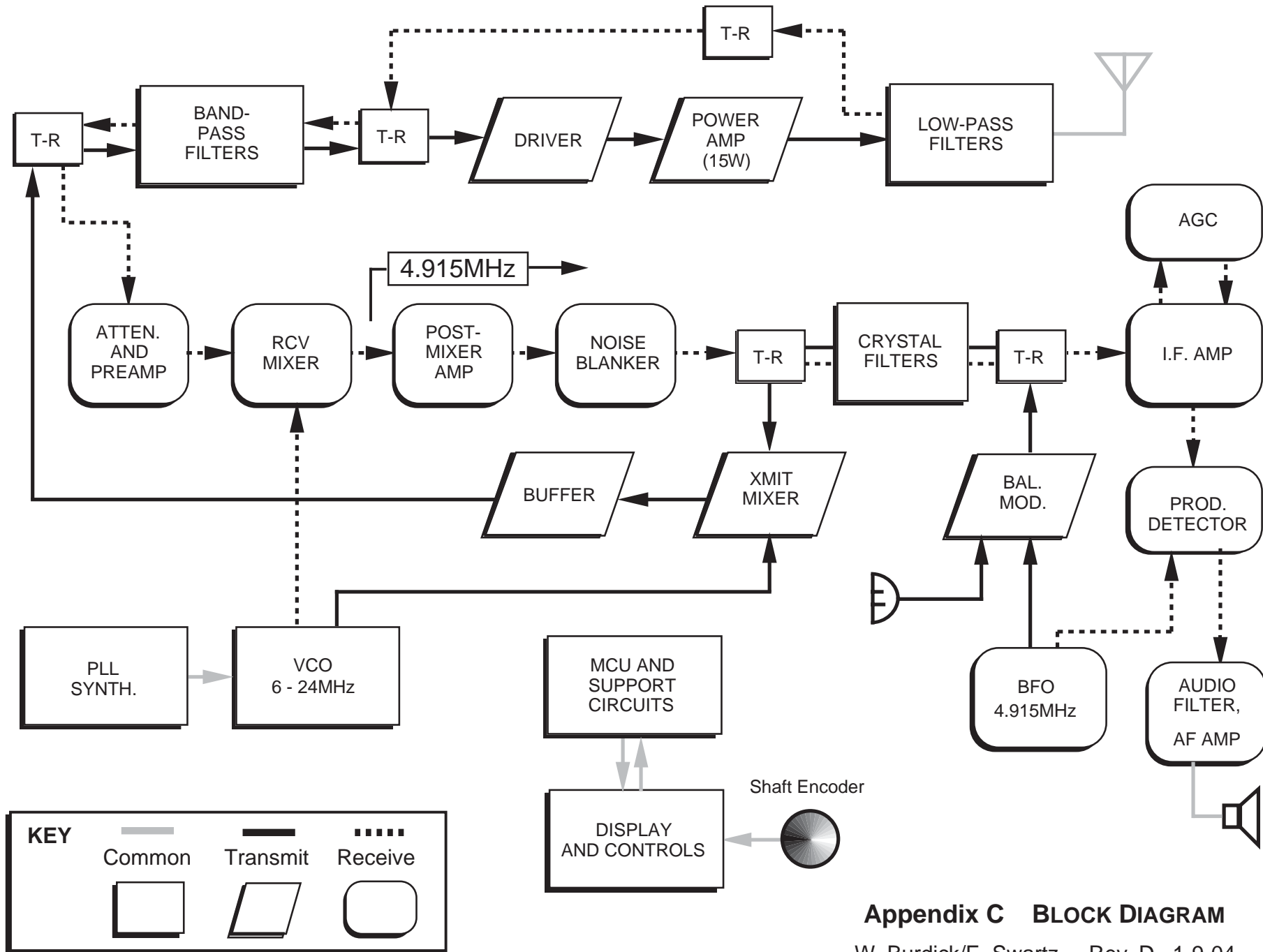

### Appendix C BLOCK DIAGRAM

W. Burdick/E. Swartz Rev. D 1-9-04

## Relay Table

### SET Relays

Band	BPF	LPF	VCO
160m	K2	160m-K1	-
80m	K2, K3	K8	K13
+60m	K1, 60m-K1	K12	K13, K14
*40m ALT	K1	K12	K13, K14
40m	K1	K12	K14
30m	K3, K4	K9	K14, K15
20m	K4	K9	K13, K14, K15
17m	K5	K11	K13, K15
15m	K5, K6	K11	K15
12m	K6, K7	K10	K13, K14, K15
10m	K7	K10	K13, K15

+ 60 meters is available only if the K60XV option is installed.

\*40m ALT applies if D19-D20 are not installed.

NOTE: All relays are single-coil latching type and are shown in the RESET position in schematics.

Relay pins 5 and 6 are not connected internally.

## Diodes



## Transistors

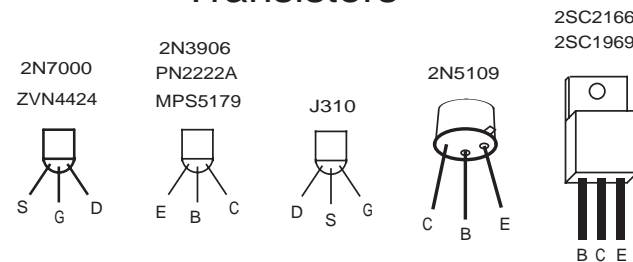

## Integrated Circuits

PLASTIC DIP  
(DUAL-INLINE PACKAGE)

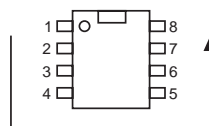

COUNT PINS STARTING AT  
PIN 1 AND GOING COUNTER-  
CLOCKWISE (8-PIN DIP SHOWN)

VOLTAGE REGULATORS

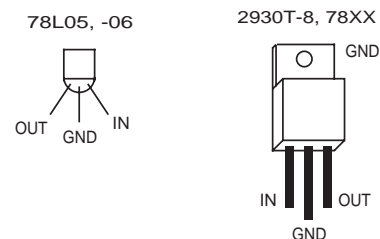

## Special Symbols

= On bottom of PC board.

= Jumper

## VCO Table

Band	Fixed Cap., pF	Total Cap., pF*	VCO Freq. at band edge**
160m	C75 (470)	525-629	6715 (subtract)
80m	C72 (270)	325-429	8415 (subtract)
60m	C71+C73 (129)	215-259	10165 (subtract)
***40m ALT	C71+C73 (129)	163-209	11915 (subtract)
40m	C71 (120)	154-203	11915 (subtract)
30m	C73+C74 (67)	102-131	14915 (subtract)
20m	C74 (20)	55-84	18915 (subtract)
17m	none (0)	35-64	22915 (subtract)
15m	C73 (47)	82-111	16085 (add)
12m	C74 (20)	55-84	19975 (add)
10m	none (0)	35-64	23085 (add)

\* This includes capacitance of varactor diodes D23-D26 on all bands, D21-D22 on 80 -160 m, and D19-D20 on 40 and 60 meters (if applicable). Only a portion of the indicated capacitance range is actually used to cover each Amateur band segment. VCO frequency can be calculated based on a total inductance of 0.95  $\mu$ H (T5 in parallel with L30).

\*\* Based on an I.F. of 4915 kHz (e.g., 6715 - 4915 = 1800).

5250 kHz used as 60-meter lower band edge (pending U.S. FCC ruling).

\*\*\*40m ALT applies if D19-D20 are not installed.

### Elecraft K2 Schematic Key

By W. Burdick E. Swartz	Rev. D	Date 10/23/02	Sht. 1 of 1
----------------------------	-----------	------------------	----------------

## Appendix B

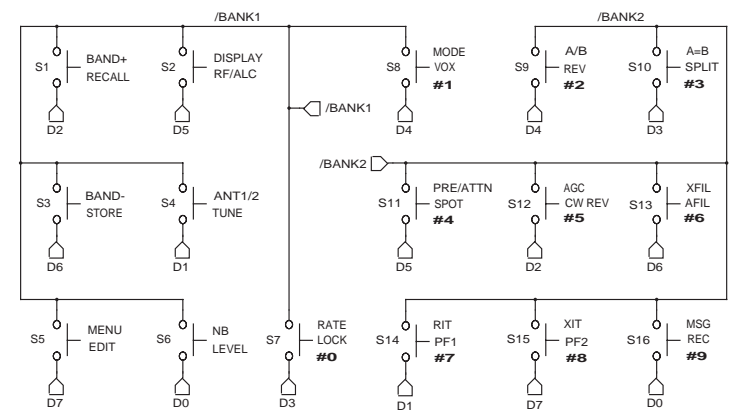
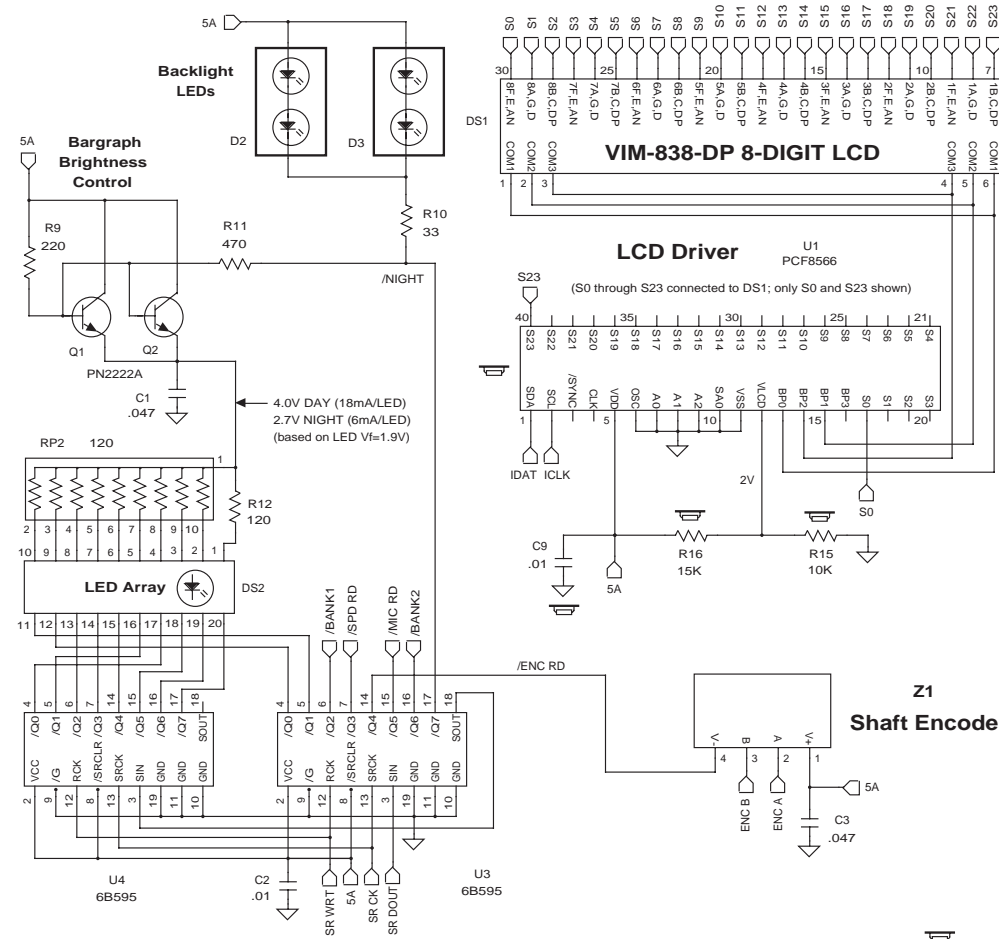

**Pushbutton Switches**

First switch label corresponds to switch TAP. Second label corresponds to switch HOLD. S7 - S16 can also be used as a numeric keypad.

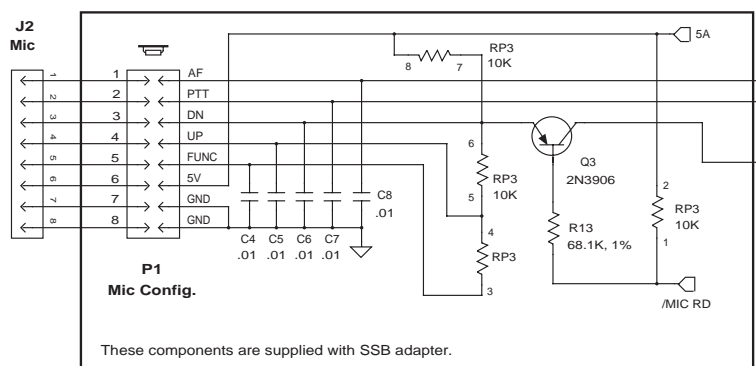
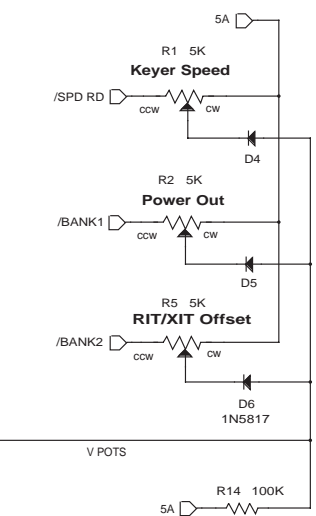
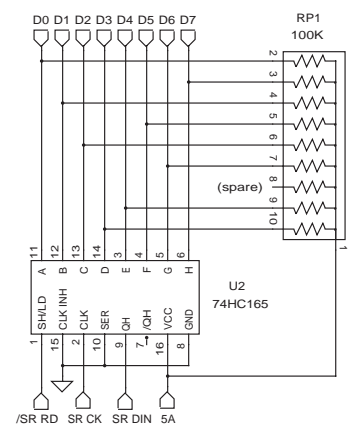

These components are supplied with SSB adapter.

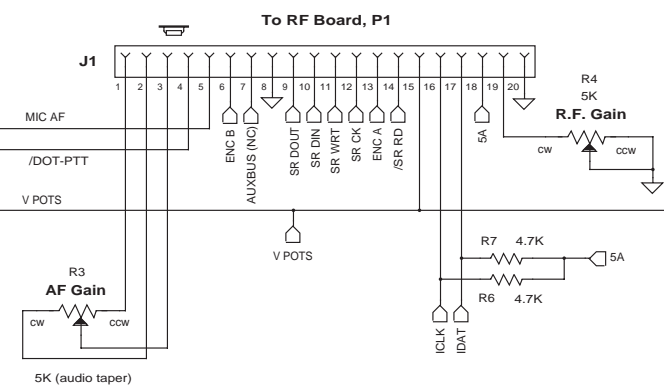

Elecraft K2 Front Panel Board			
By W. Burdick	Rev. C	Date 10/6/02	Sht. 1 of 1
E. Swartz			

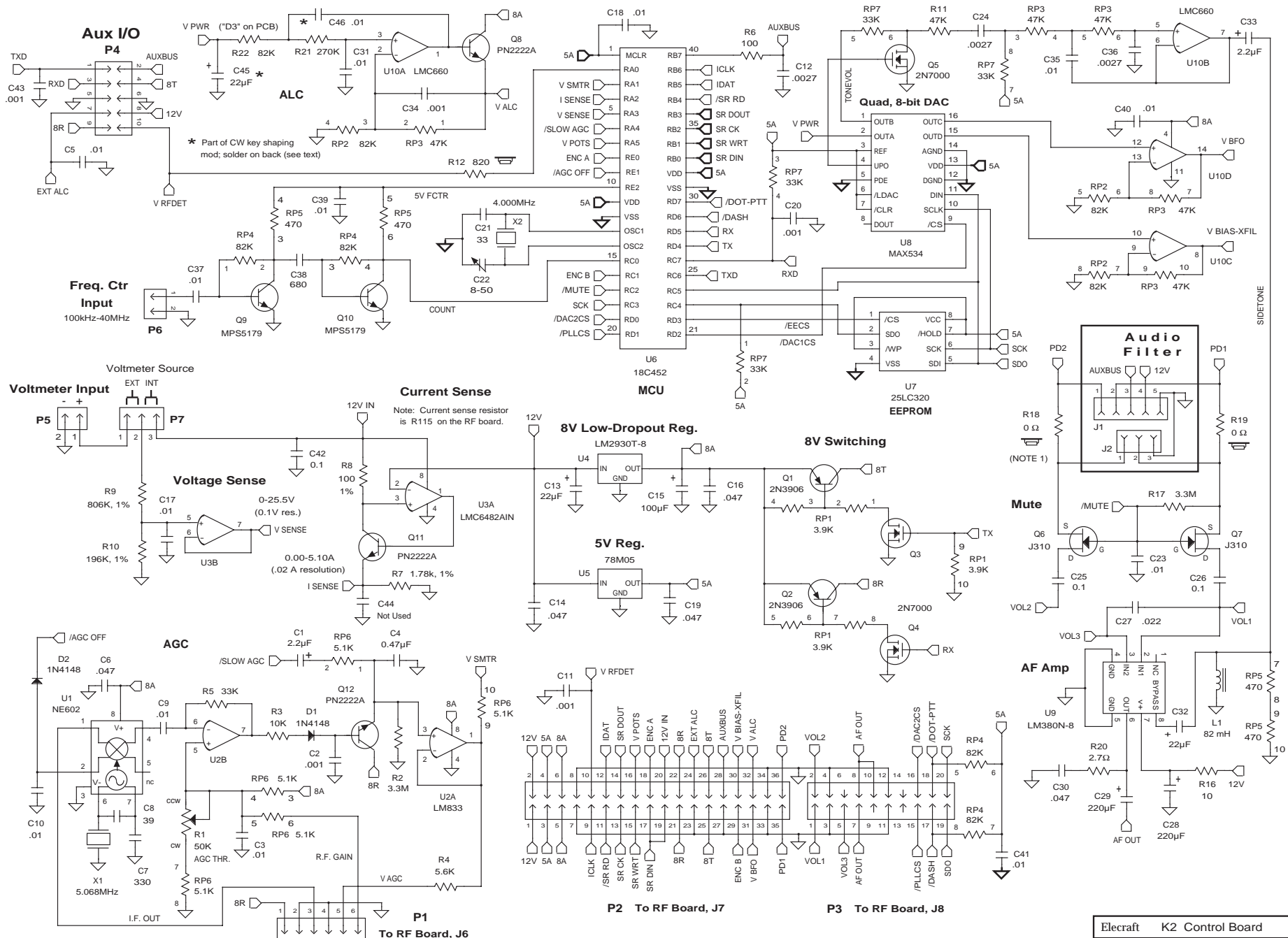

Elecraft K2 Control Board			
By W. Burdick	Rev. F	Date 1/27/04	Sht. 1 of 1
E. Swartz			

NOTE 1: Jumpers are used at R18 and R19. They must be removed if the Audio Filter option is installed.

= on bottom of PCB board

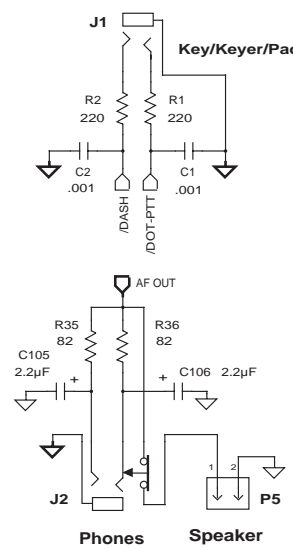
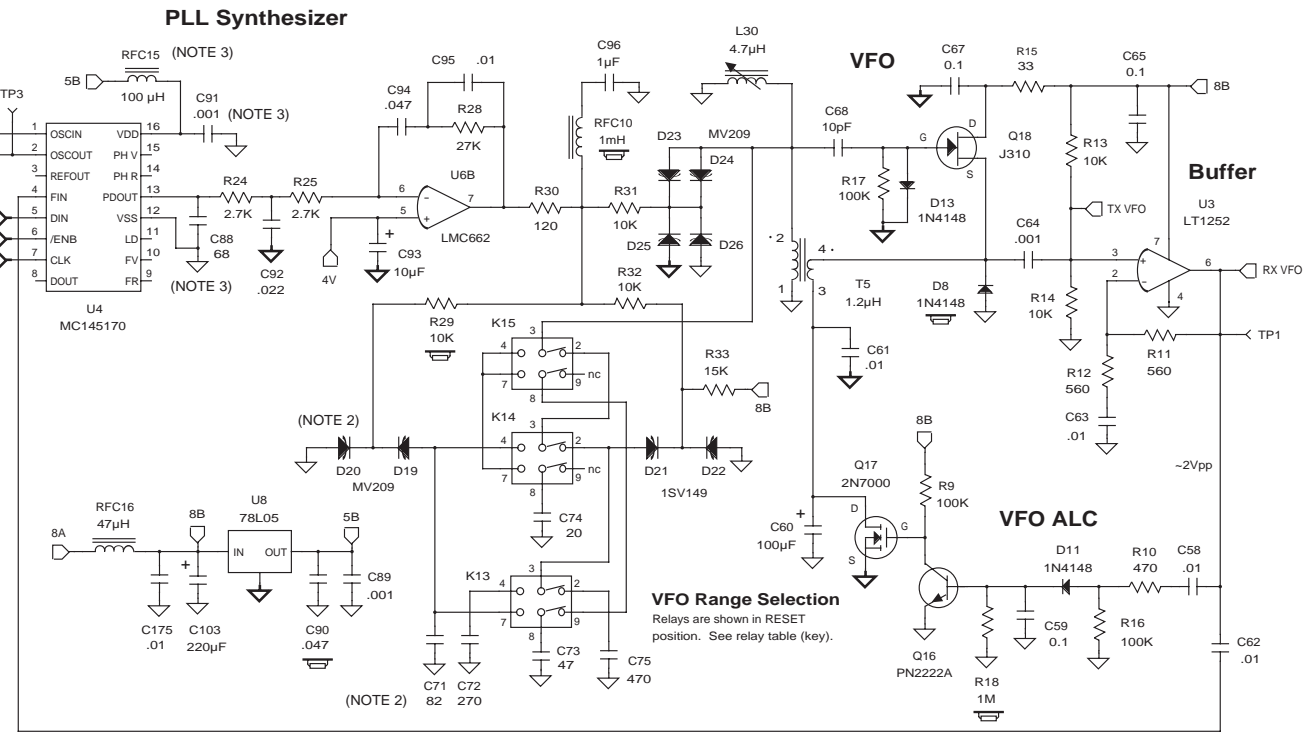
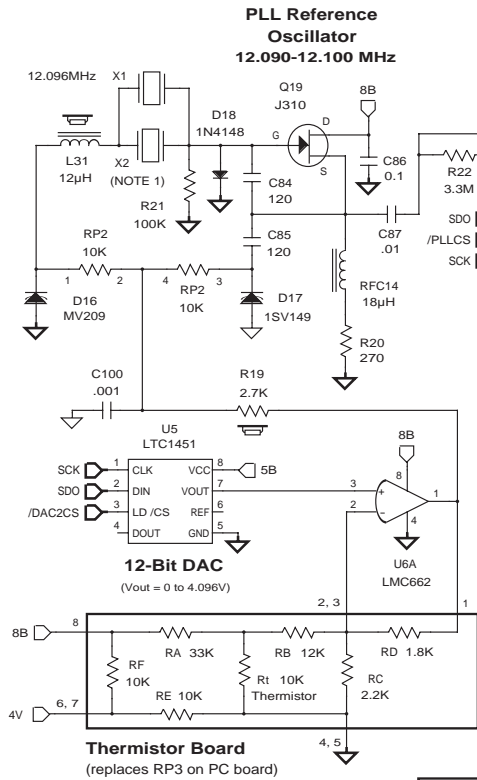

NOTE 1: X2 is not used.

NOTE 2: D19-D20 are supplied with the K60XV option. They must not be installed unless the K60XV option is also installed (60 m band and transverter I/O). C71 must be changed to 120 pF if D19-D20 are installed.

NOTE 3: These components improve PLL stability; they must be soldered on the back of the board (see text).

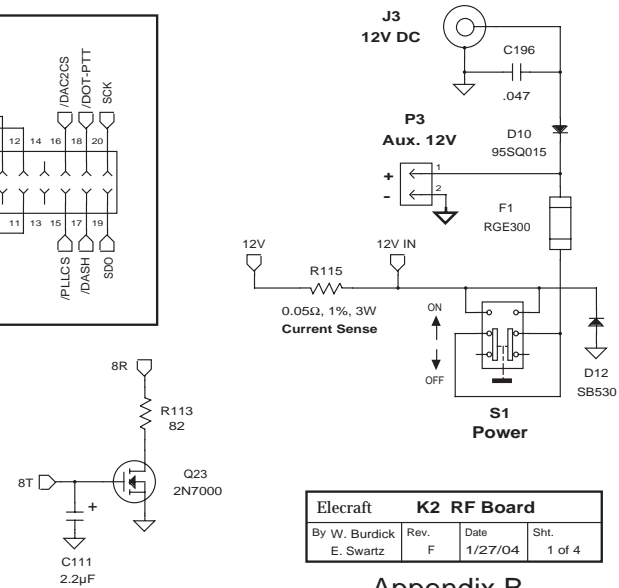
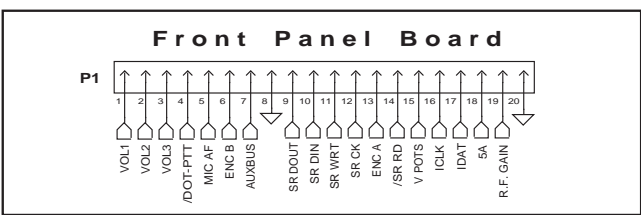
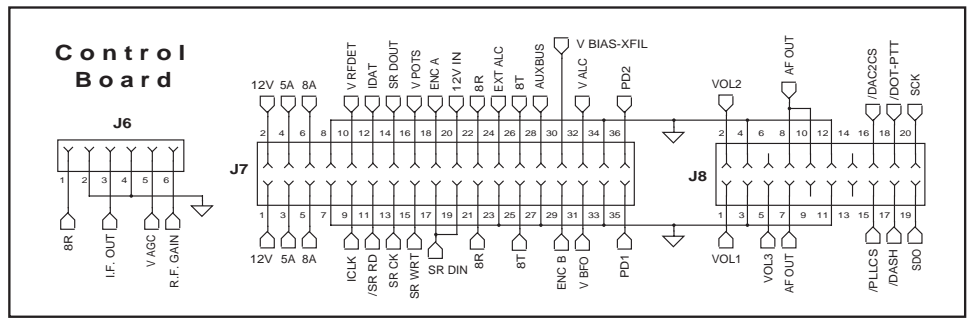

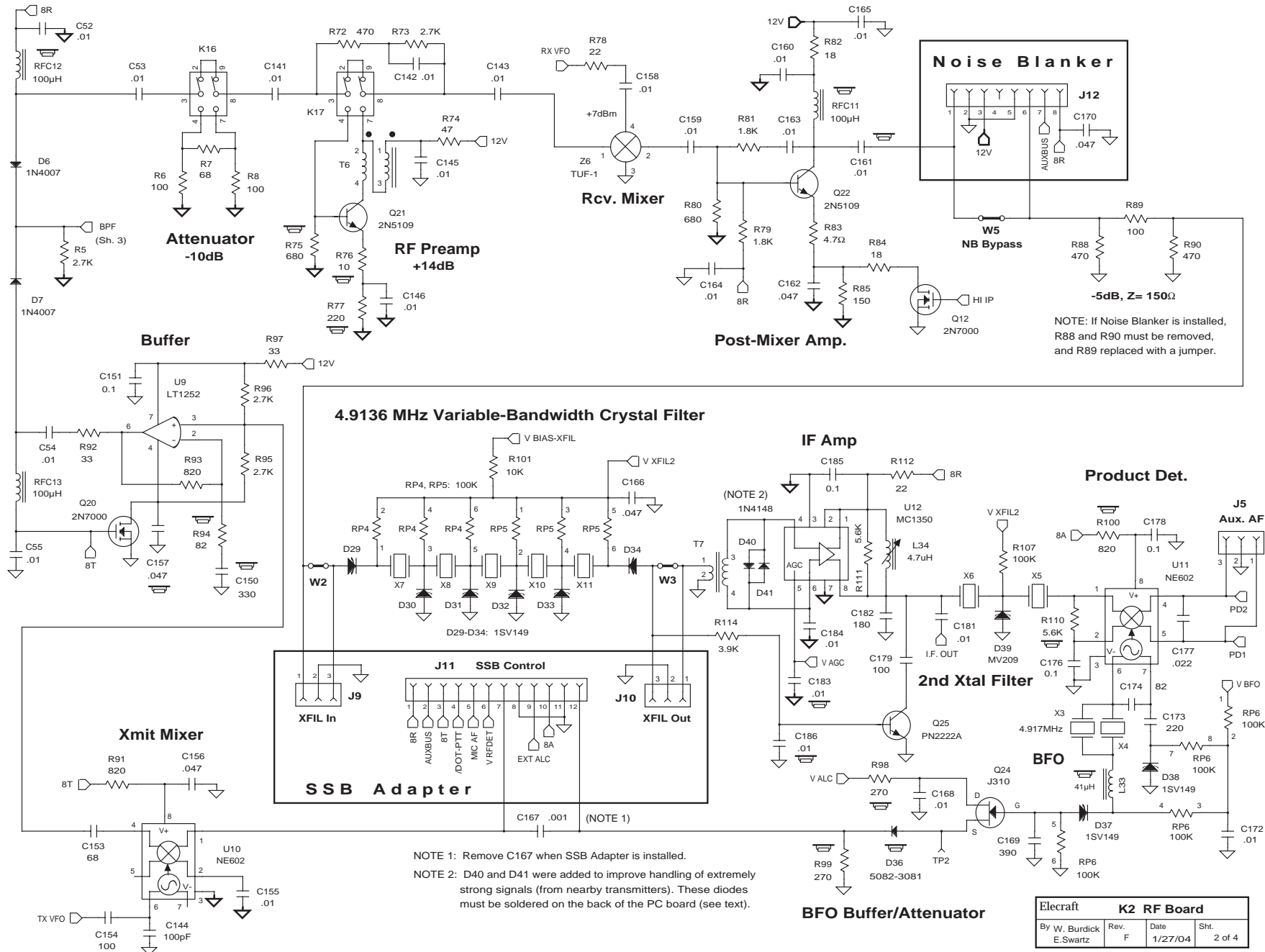

Elecraft K2 RF Board			
By W. Burdick E.Swartz	Rev. F	Date 1/27/04	Sht. 2 of 4



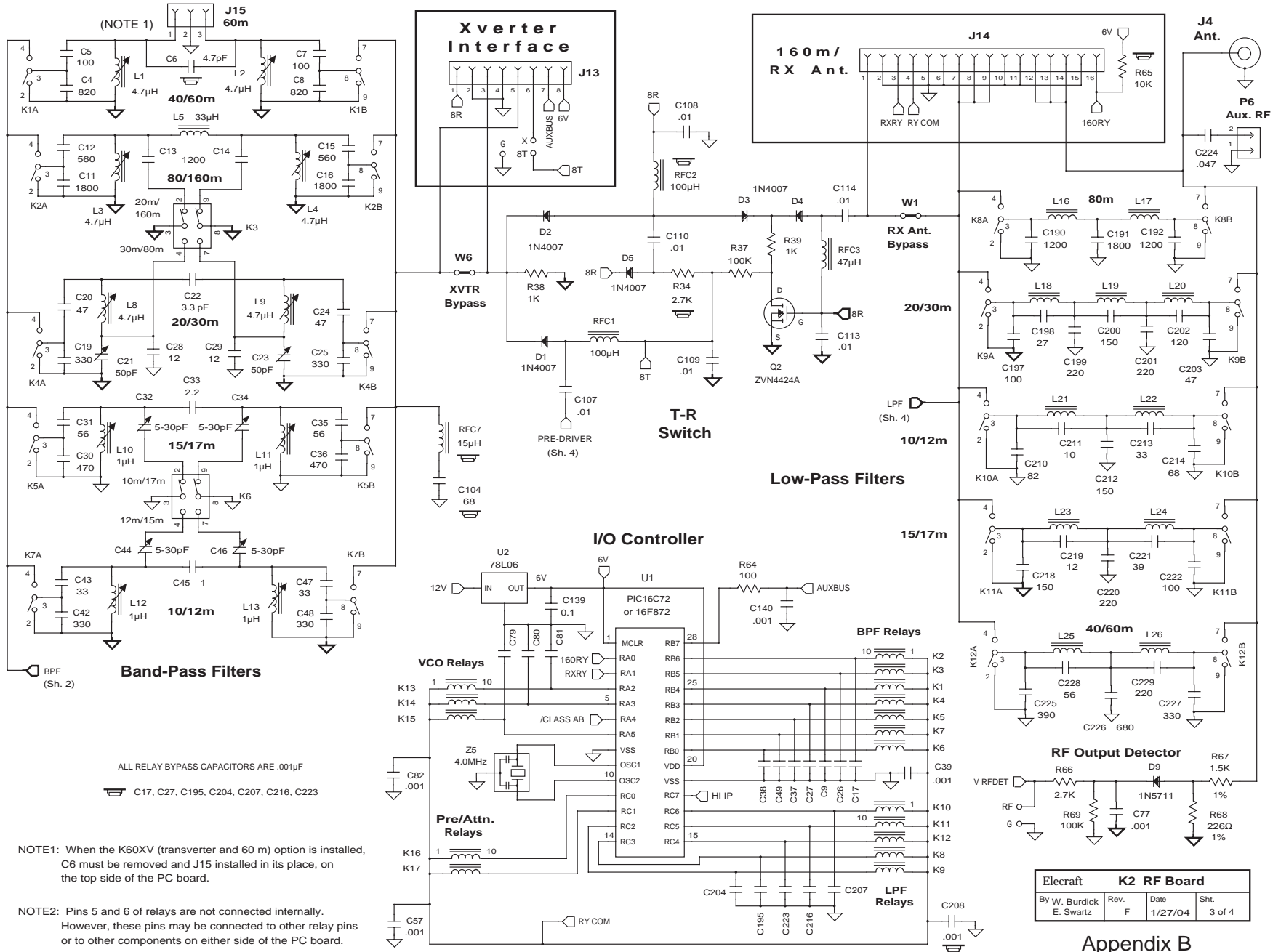

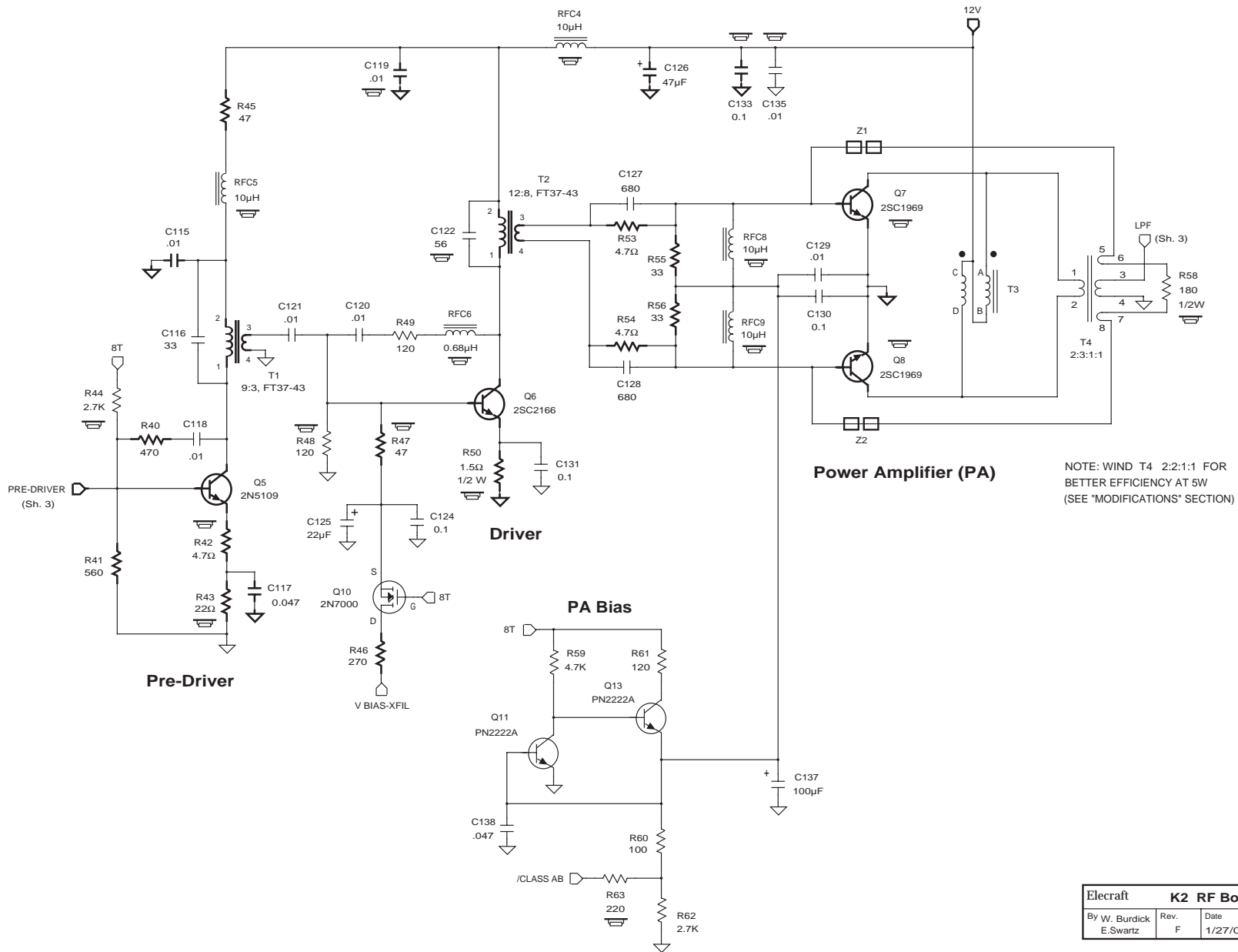

NOTE: WIND T4 2:2:1:1 FOR BETTER EFFICIENCY AT 5W (SEE "MODIFICATIONS" SECTION)

Elecraft			
<b>K2 RF Board</b>			
By W. Burdick	Rev.	Date	Sht.
E. Swartz	F	1/27/04	4 of 4

Appendix B

# K2 KIT CHANGES AND MANUAL ERRATA

Rev. F-2, Feb. 26, 2004

<p><b>PLEASE READ THIS INFORMATION BEFORE YOU BEGIN ASSEMBLY</b></p>
--

**Your K2 kit includes a number of recent upgrades to both hardware and firmware. These include:**

- Modified CW keying envelope to significantly reduce transmit bandwidth
- Limiting diodes on the receive I.F. amplifier input to cleanly handle nearby transmitters operating on your exact frequency (characteristic of "HF Pack" style operation)
- Two new scanning modes, including "channel hopping" (among in-band frequency memories) and "live scan" (unmuted scanning for use in locating very weak signals)
- Up to six transverter band displays
- Transverter address control to allow more than one transverter band to select a given XV-series transverter
- Full support for the forthcoming K60XV option, which will provide 60 meter capability and low-level transverter I/O (due in March, 2004)

Errata Items:

1. **Page 47, right column, 2nd assembly step:** This step was supposed to be on page 64, right column, just before "Assembly, Part III". Make a note on page 64 referring to the step on page 47.
2. **Page 57, right column, 2nd assembly step:** Change L31 from 12  $\mu$ H to 10  $\mu$ H.
3. **Page 82, rear panel drawing:** The illustration shows a new lower rear panel that includes holes for two additional transverter in/out jacks (RCA connectors). Your kit may not have this new rear panel because it was being phased into production at the time the manual was written. You can obtain the new rear panel later if you plan to purchase the K60XV option (60 meters and low-level transverter I/O). Availability of this option will be announced.
4. **Appendix A, RF board parts list, page 5:** Change L31 from 12  $\mu$ H to 10  $\mu$ H. Also make this change on the schematic (Appendix B, RF board sheet 1, upper left corner).

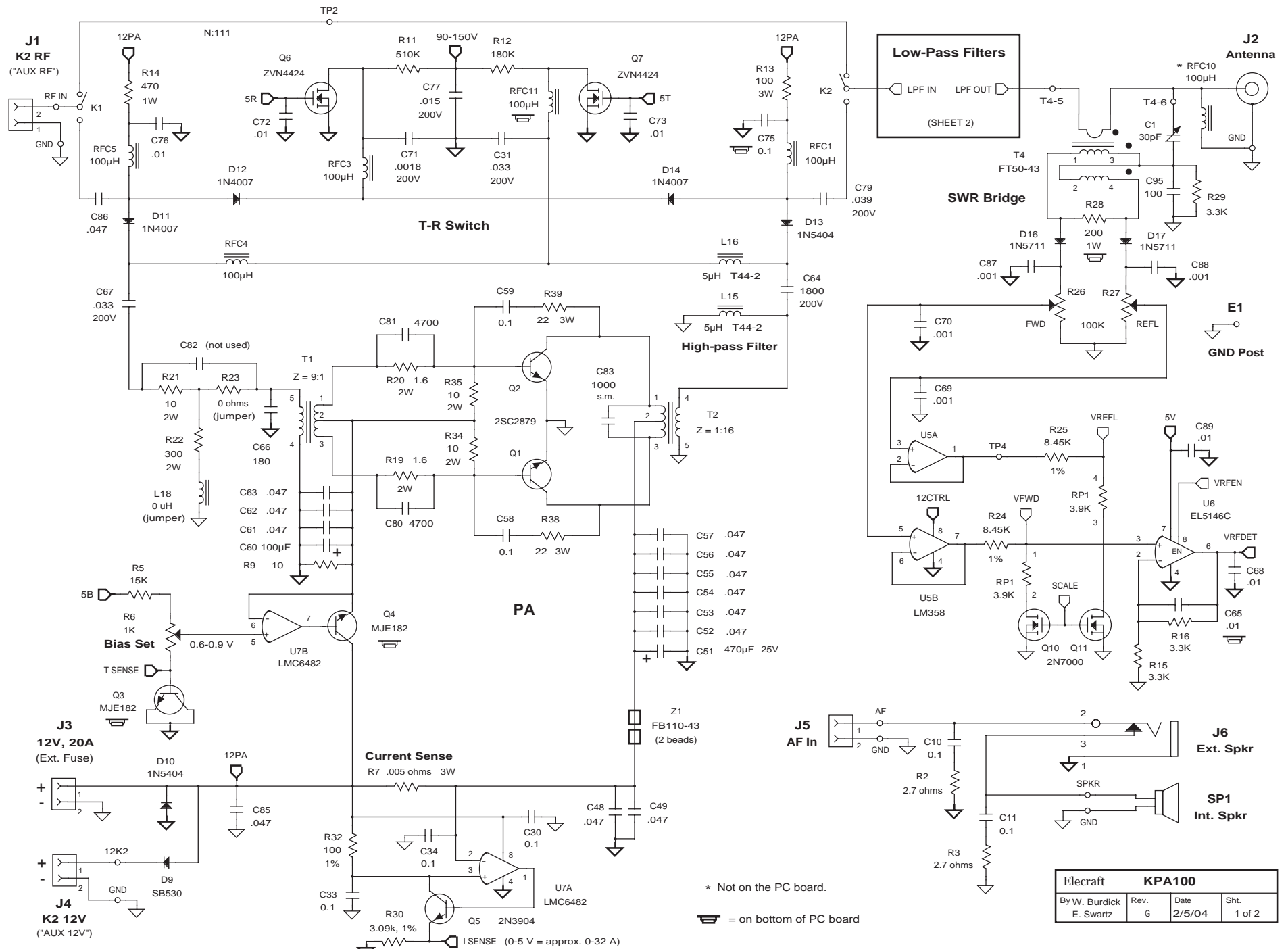

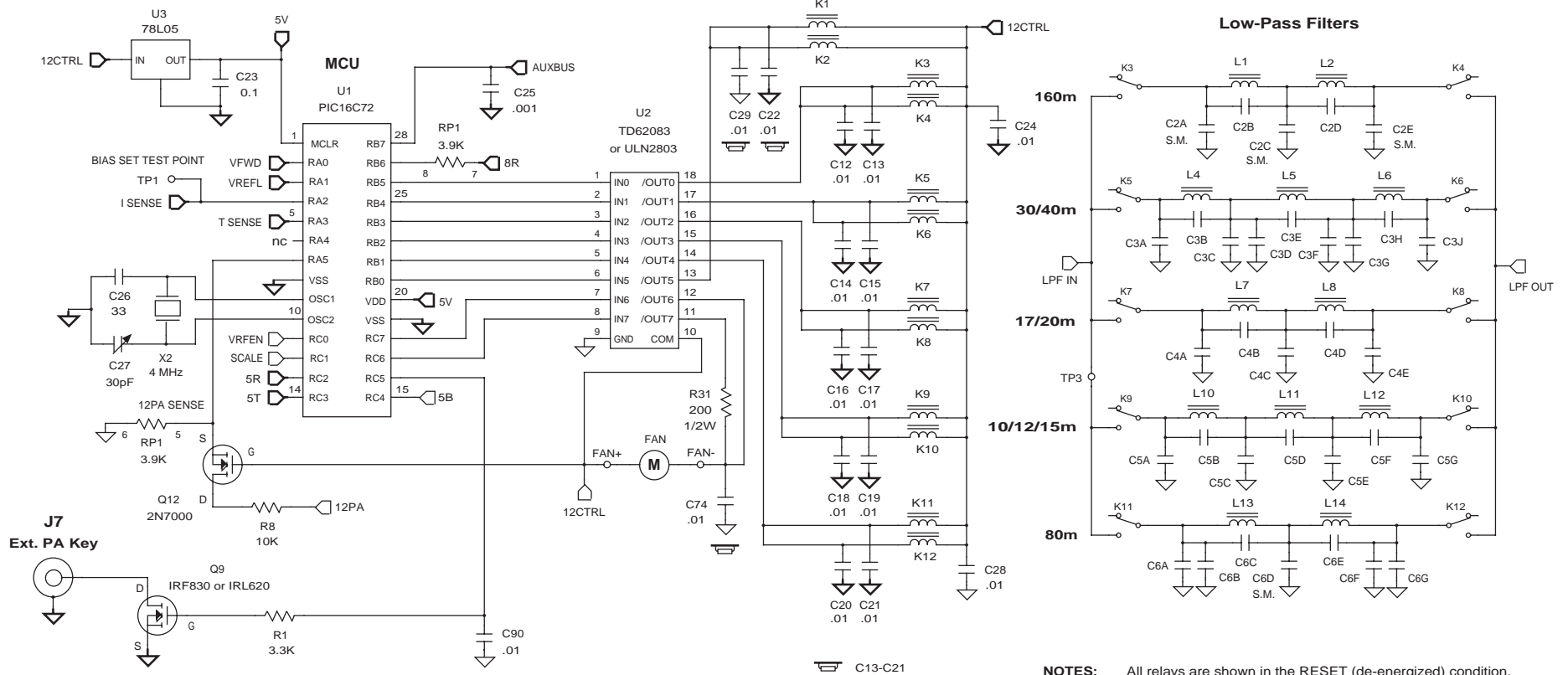

**Low-Pass Filters**

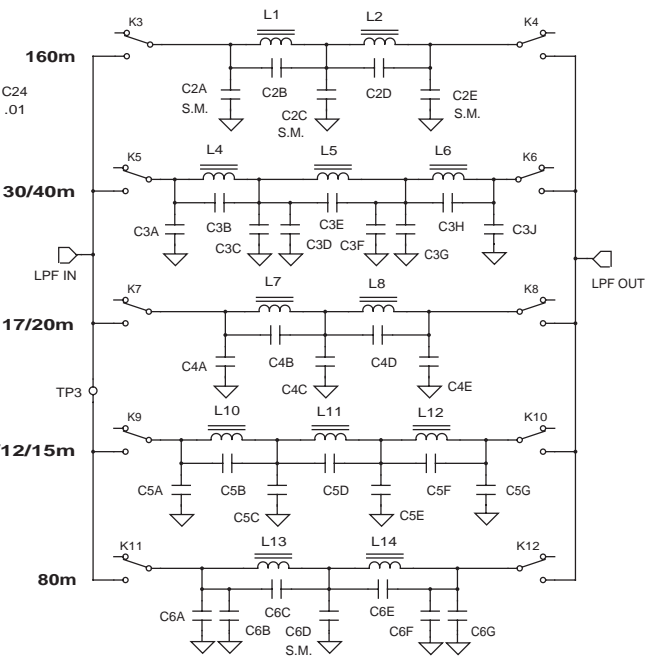

**NOTES:** All relays are shown in the RESET (de-energized) condition.  
 = on bottom of PC board (nearest the heatsink).

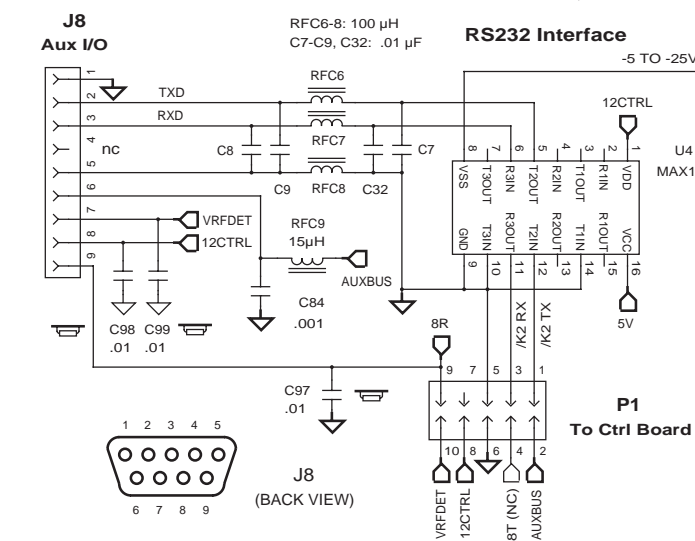

**High-Voltage Bias Supply**

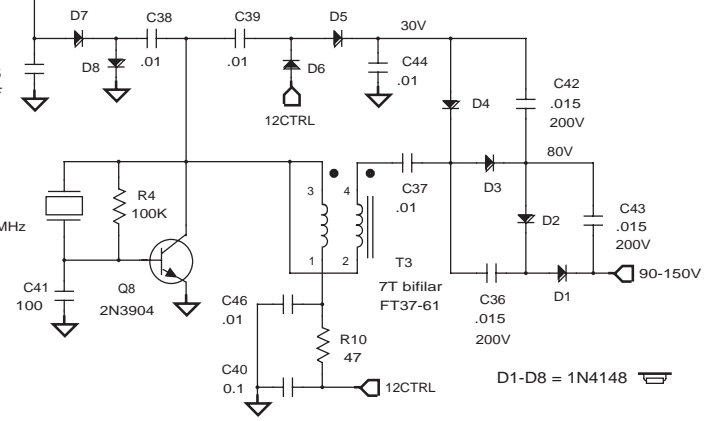

Elecraft		KPA100	
By W. Burdick	Rev. G	Date 2/5/04	Sht. 2 of 2
E. Swartz			

# K2/100 MANUAL (Appendix G) ERRATA

Rev. C-3, December 14, 2004

## PLEASE READ BEFORE YOU BEGIN ASSEMBLY

### Important Notice

Your KPA100 kit includes recent circuit changes that allow the K2/100 to handle higher mismatch conditions, allowing power reduction to start at an SWR of 2:1 rather than 1.5:1.

Since your kit is one of the first shipped with these enhancements, it may include an unused toroid core, a few extra resistors, and an extra capacitor (the previous component values).

### Errata Items

1. **Page 7, parts list:** Change R4 from 100 k to 39 k. (Your kit may include an unneeded 100 k resistor.) Add resistor R33 to the parts list (1 k, 5%, 1/4 W, BRN-BLK-RED).
2. **Page 13, left column, 2<sup>nd</sup> assembly step:** Change R4 from 100 k to 39 k.
3. **Page 13:** Cut out and tape this assembly step at the bottom of the right column:  
  
\_\_ Locate a 1 k, 1/4-watt resistor (R33). Trim R33's leads to approx. 1/4" (6 mm) long. Place the resistor across the leads of RFC3 (RFC3 is near the fan and the large black RF choked marked "101"). Solder the resistor to RFC3's leads.
4. **Page 24, left column, first paragraph:** The second sentence in this paragraph should be replaced with: "Each toroid is wound on a specific type of core. One example is type T44-2."
5. **Page 24, right column, first assembly step:** The reference to a T50-2 core in this paragraph should be changed to T50-10.
6. **Page 47:** Cut out and tape this test step at the bottom of the left column:  
  
\_\_ Set your DMM for 200 or 300 VDC full-scale. Connect the (-) lead of the DMM to ground (one of the KPA100 standoffs). Be ready to touch the (+) lead to the left side of 180-k resistor R12 (the lead closest to RFC5). Turn on the K2 and select CW mode. Set the power knob above 11 W. Hold the MODE button down 1-2 seconds to enter CW TEST mode. Press the TUNE button and verify that the DC voltage at the left side of R12 is 100-110 VDC or more. Exit TUNE by tapping any button. Exit CW TEST mode by holding down the MODE button.
7. **Schematic:** On page 64, add R33 (1 k) across RFC3, in the T-R switch. On page 65, change R4 from 100 k to 39 k in the High Voltage Bias Supply.

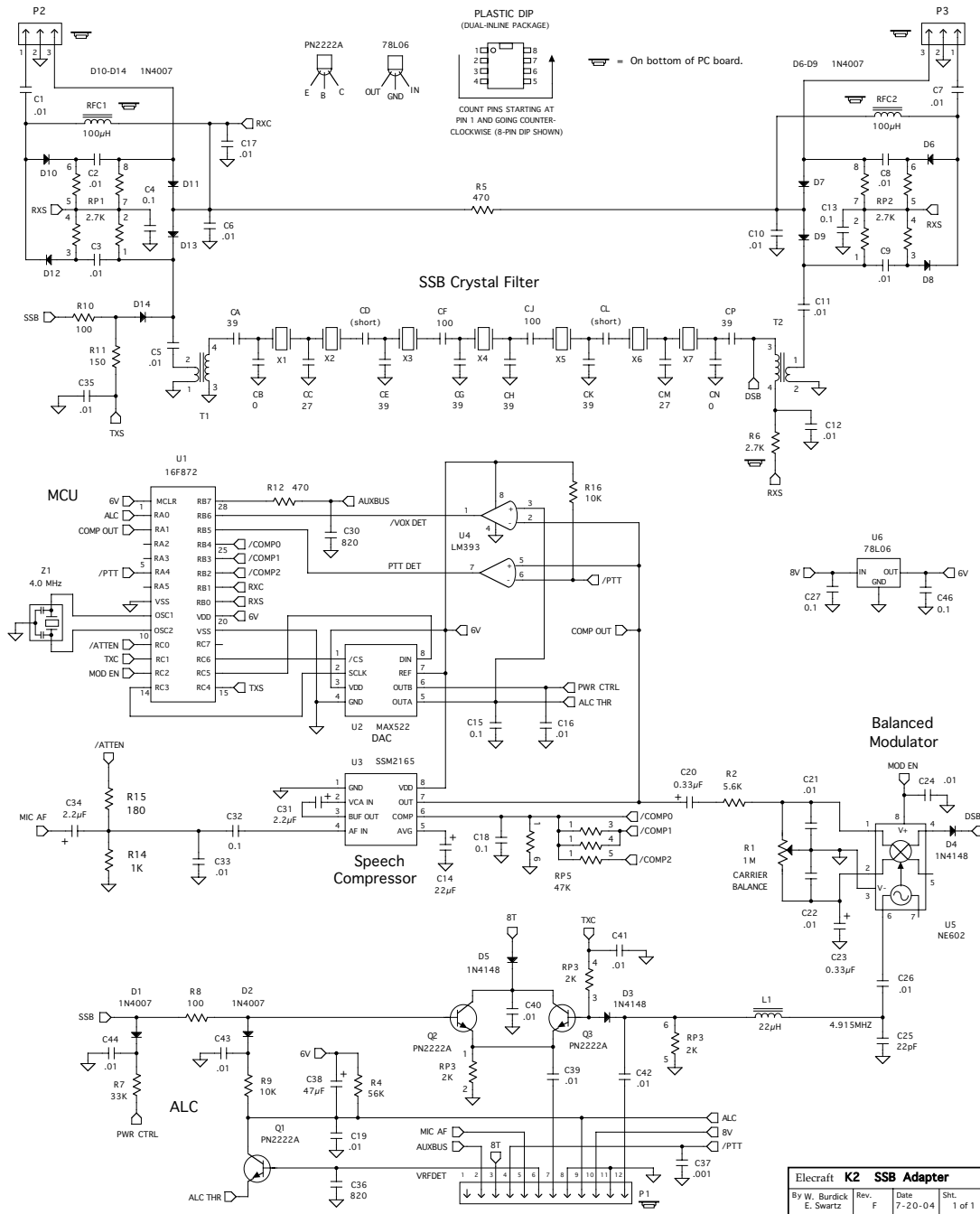

# Elecraft SSB B/W Modification (SSBCAPKT) Installation Instructions

Revision A, November 9, 2004. Copyright © 2004, Elecraft; All Rights Reserved

## Parts Inventory

P/N	Description	QTY
E530016	100 pF, 100V,5%,NPO,0.1LS, CAP	2 EA
E530049	150 pF,100V,5%,NPO,0.2LS, CAP	2 EA
E530141	27 pF, 200V,5%,NPO, 0.1LS, CAP	2 EA
E530144	33 pF, 50V, 5%, NPO, .1LS, CAP	4 EA
E530152	39 pF, 50V, 5%, NPO, .1LS, CAP	6 EA

## Introduction

The Crystal Filter Bandwidth Modification capacitor kit provides two options to change the original 2.1 kHz 6 dB bandwidth of the KSB2 SSB filter to either 2.4 kHz or 2.6 kHz. (**Note:** KSB2s shipped after July 12, 2004 now include the 2.4 kHz bandwidth components.) These modifications are not *required* for the K2 to function well in the SSB mode. Instead, they are intended for those who wish to optimize its performance to their personal preferences.

The 2.4 and 2.6 kHz bandwidth filters also require better matching of crystal motional inductance to minimize pass-band ripple. We have worked with our supplier to obtain crystals with better control of the motional inductance. The latest ones now make it possible to increase the SSB filter bandwidth up to 2.6 kHz. **The latest crystals (shipping with all KSB2s since May 2002) are marked with “ECS 4.9136-S” on each crystal. Older crystals shipped before May 2002 marked with “ECS 4.91-20” or “ECS 4.91-0195” should be replaced when performing this modification.**

The older crystals work fine at a 2.1 kHz bandwidth, but are not optimum for wider bandwidths. If you want to add a wider SSB bandwidth enhancement to your KSB2, we suggest you order a new set of crystals from Elecraft. They are Elecraft Part #E850006 (7 matched crystals for the KSB2) or #K2KSB2XTLS (14 crystals for the KSB2 and the K2 CW filters.) See our spare parts order page at [http://www.elecraft.com/order\\_form\\_parts.htm](http://www.elecraft.com/order_form_parts.htm)

## Removing parts from the KSB2

The KSB2 is designed with much smaller pad sizes than the other boards in the K2 transceiver. For this reason it can be more difficult to remove parts without damaging the board. If you don't have a desoldering tool, cut the leads off the part and then pull out each piece of wire individually. You will lift pads on the KSB2 if you try to remove capacitors in one piece. Sacrifice the part and save the board. Crystals may be removed by desoldering the grounding lead on the top and then wiggling the crystal out by alternately heating each pad on the board.

The best way to remove parts from a KSB2 is to use a Hakko 808 (or equivalent) de-soldering tool. If you are interested, the Hakko 808 and tips for it are available at <http://kiesub.com/hakko808.htm> .

## Crystal Filter Bandwidth Modification

The KSB2 filter as designed has a 2.1 kHz bandwidth. The response of a crystal ladder filter can be adjusted by changing the capacitors in the filter. The most critical capacitors are the ones that connect to ground between each pair of crystals. These capacitors set the coupling between the filter sections. The capacitors in series with a crystal modify the resonant frequency of each section, but are not nearly as critical in value.



**The wider bandwidth filters require that the BFO be tuned to a higher frequency for receiving USB on the lower bands.** For the 2.4 kHz bandwidth, the BFO must be able to reach approximately 4916.5 kHz and for the 2.6 kHz bandwidth it must reach approximately 4916.8 kHz. Be sure and check your maximum BFO frequency before attempting to use a wider filter bandwidth. To measure BFO frequency, attach your K2 frequency probe to TP2 and use CAL FCTR to read the BFO frequency. While in this mode, press BAND UP to set the BFO to its max frequency and BAND DOWN to set it to its minimum frequency. It may be possible to increase the maximum BFO frequency in a K2 by removing turns off of L33 or changing capacitor sizes without raising the minimum frequency too high. Contact [support@elecraft.com](mailto:support@elecraft.com) if you have questions regarding changing the maximum BFO frequency.

The following table shows the new capacitors for each reference designator (CA, CP etc.) on the KSB2 board. Remove the old capacitors and install the new ones as indicated for your chosen bandwidth in the table. If necessary (as noted above) also remove and replace the crystals.

After installation you will need to re-optimize your USB and LSB transmit BFO settings (BF1t) in CAL FIL. See 'Transmit BFO Optimization' on page 22 of the latest KSB2 manual. (Available on our manual download web page at <http://www.elecraft.com> )

Nominal BW (kHz)	Predicted 6 dB BW (kHz)	Predicted Loss (dB)	Predicted Ripple (dB)	CA,CP (pF)	CB,CN (pF)	CC,CM (pF)	CD,CL (pF)	CE,CK (pF)	CF,CJ (pF)	CG,CH (pF)
Original	2.1	8.3	3.2	100	10	33	Short	47	56	47
2.4	2.4	7.5	1.5	39	Open	27	Short	39	100	39
2.6	2.65	7.3	1.9	39	Open	27	Short	33	150	33

## App. Note: Using Spectrogram to make filter measurements

Spectrogram ( <http://www.visualizationsoftware.com/gram.html> ) may be used to measure the response of the K2 filters with your PC sound card. To make a measurement of a K2's filter, use the following procedure:

1. Connect a noise generator to the antenna input of the K2 (Elecraft N-gen etc.). Using antenna noise for this purpose will be much less accurate.
2. Connect the audio output of the K2 to the sound card input on a PC. If you use the headphone output of the K2 for this purpose, be sure to place a 10 ohm resistor to ground to avoid rolling off the high frequencies due to C105/C106.
3. If your K2 has a KAF2 or KDSP2 installed in it, be sure to put it in bypass mode. If left in line, the higher audio frequencies will be attenuated and will decrease your amplitude measurement accuracy.
4. Set Spectrogram at Scan Input to 22k Sample Rate, 16 bit Resolution, Line Plot, 90 dB Scale, 1024 FFT, and Average Count to 32. Then press OK. Move the slider at the right to the top of its range. The displayed spectrum should not exceed -30 dB or you risk overloading the sound card input.
5. Set the K2 to 7100 kHz. Turn AGC Off. Set the AF Gain to about its mid-point. Select the filter for which you wish to measure its frequency response. Adjust the RF Gain so that the maximum level displayed is -30 dB or less.
6. If you wish to see the KSB2 SSB filter response without it being modified by the K2's 2nd Xtal Filter, place 0.1uF caps across X5 and X6 on the RF Board.
7. When you have completed the measurements, return the KAF2 or KDSP2 , if present, to its normal mode.
8. Spectrogram provides an easy way to look at the filter responses of all of the K2's filters. You are limited to a dynamic range of less than 60 dB. The noise fluctuations will be several dB, but you can reduce this by increasing Average Count to 128. Additional reductions can be accomplished by averaging several sets of readings.

## K160RX Schematic

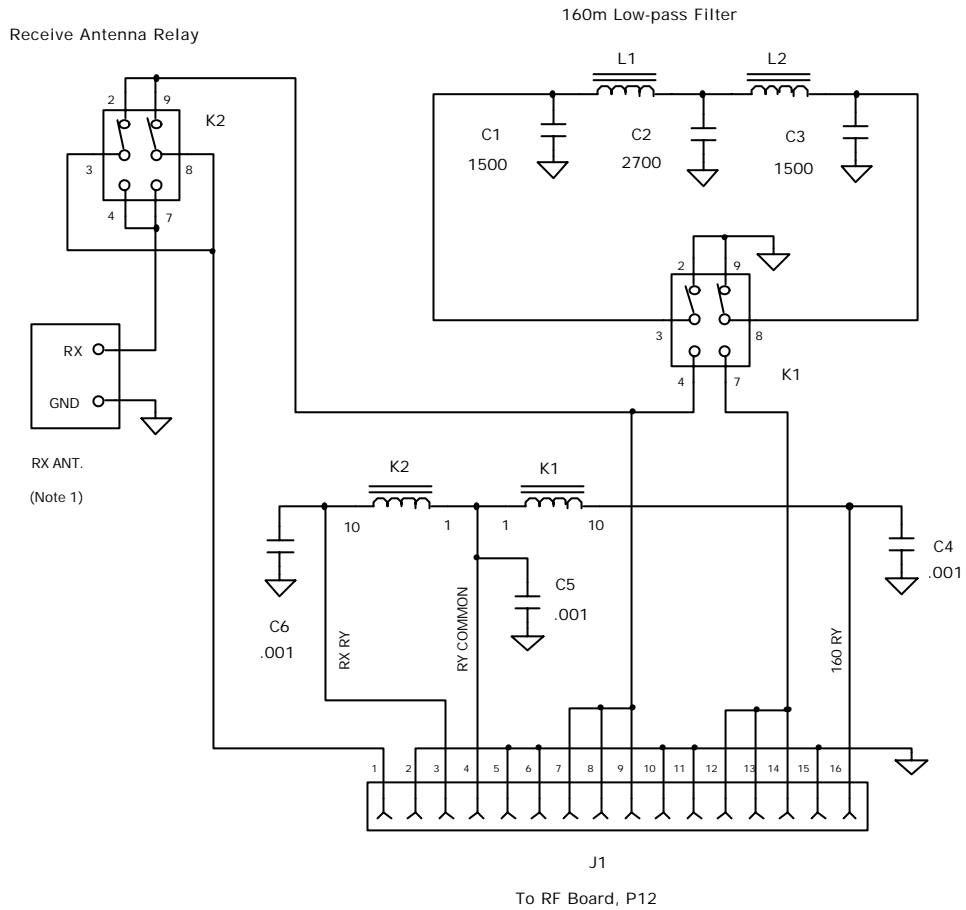

**NOTES:**

1. Remove RF board jumper W1 before using a separate receive antenna. Refer to manual for operating instructions.
2. K1 and K2 are latching relays, and are shown in the RESET position.

<b>Elecraft</b>		160m/RX ANT. Module	
By W. Burdick E. Swartz	Rev. A	Date 8-17-99	Sht. 1 of 1

## Circuit Details

U1 amplifies the I.F. signal, which is then detected by D2 (1N34A). Q1 reduces the gain of U1 in proportion to overall signal strength, keeping the signal at D2 relatively constant. Negative-going pulses that are above the threshold established by D3 and R3 turn Q2 on, triggering the one-shot (Q3/Q4). Q6 can be used to switch in a larger-value capacitor, increasing the blanking time. The pulse output of the one-shot (GATE) saturates Q5, attenuating the signal at the output of the band-pass filter. The band-pass filter creates a small delay between input and output, so that the GATE signal arrives just ahead of the noise pulses. The controller, U3, decodes auxBus commands from the main processor. It then controls power to the blanker (via Q7), pulse width (via Q6), and blanking threshold (via R3).

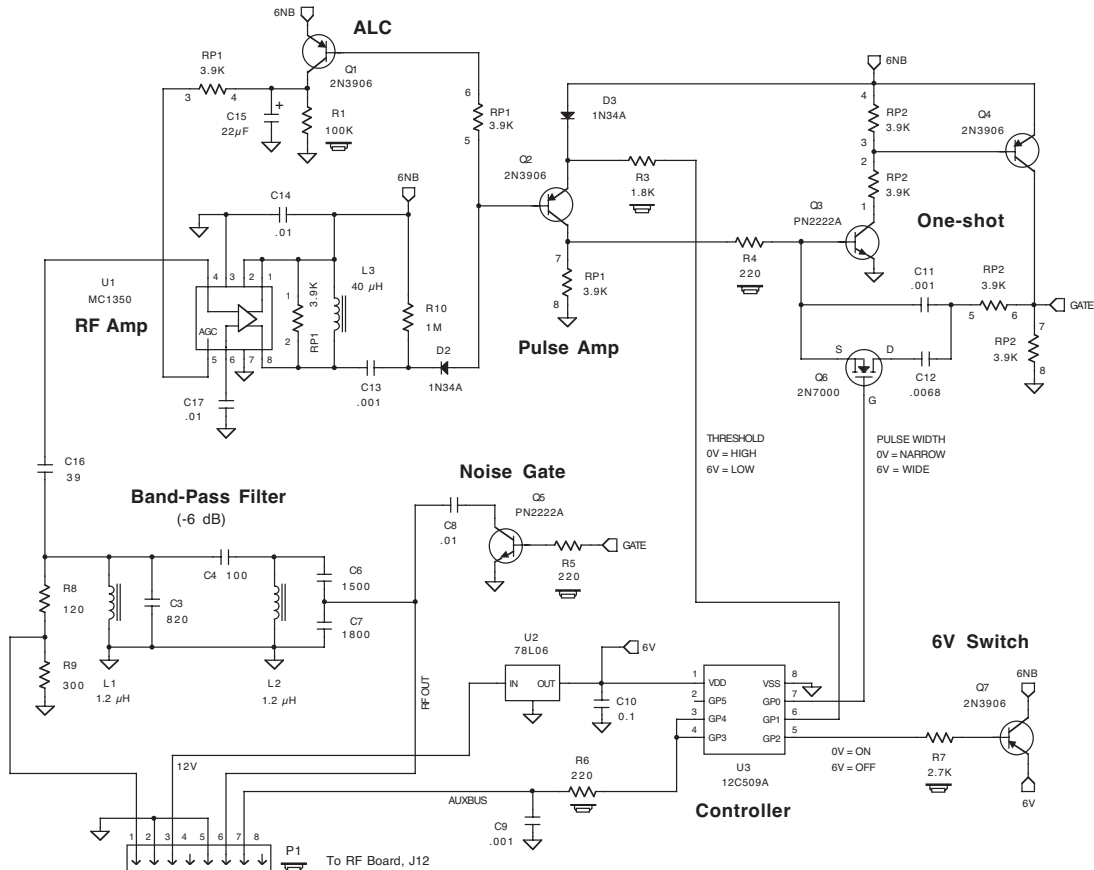

☒ = On bottom of PC board.

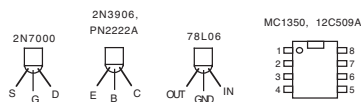

Elecraft KNB2 Noise Blanker				
By W. Burdick	Rev. D	Date	8-19-02	Sht. 1 of 1
E. Swartz				

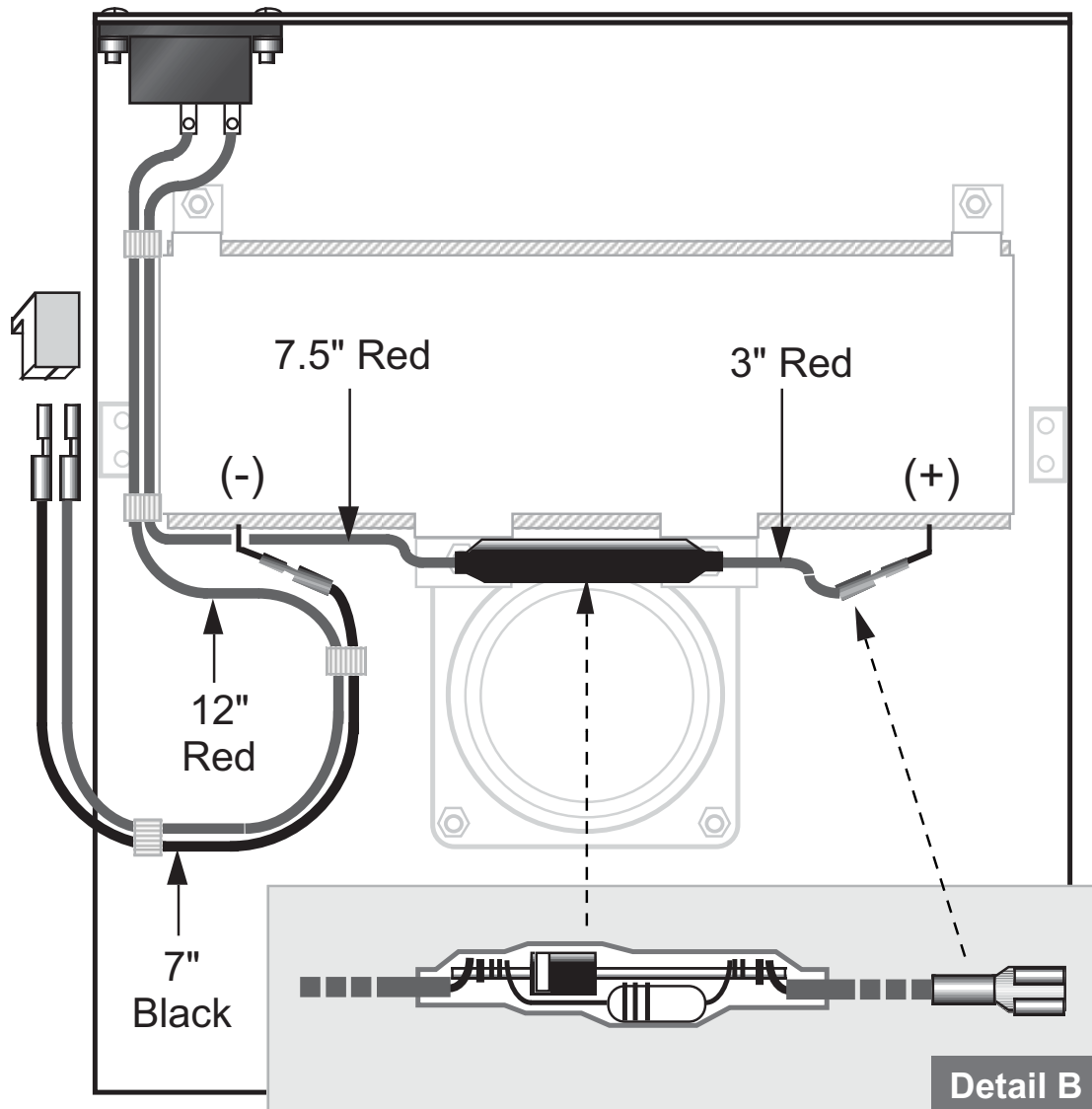

Figure 3

## Circuit Details, KAT2 L-C Board

The L-C board provides eight series inductors and eight parallel capacitors, configured as an L-network. The capacitance can be placed at the transmitter or antenna end of the network via a relay on the Control board (see next page). Each inductor and capacitor has its own DPDT relay, with the individual sections of each relay placed in parallel for reliability. The relays are selected under control of the ATU's microcontroller. Latching relays are used so that they will not consume any power except when the operator is actually tuning. The relays are switched one at a time to keep switching current low and to provide acoustically and electrically quiet operation. This results in somewhat longer tune times.

For additional reliability, the connectors used between the L-C and control boards have gold-plated contacts, and redundant pins are used for RF signals. Bypass capacitors are used on relay control lines to prevent RF signals from reaching the microcontroller.

### L-C Board Schematic

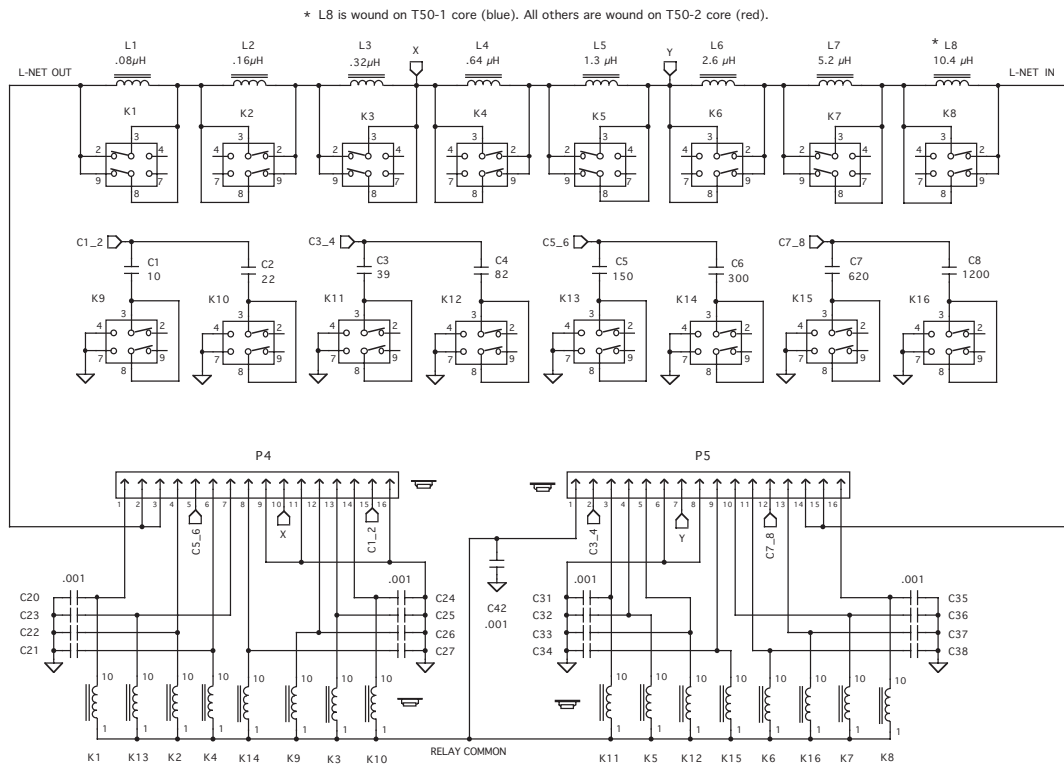

NOTE: K1-K18 are single-coil latching relays, shown in the RESET position.  
Pins 5 and 6 of each relay are used as tie points but are not internally connected.  
⏚ = On bottom of PC board. All relays on the L-C board are on the bottom.

Elecraft KAT2 ATU L-C Board			
By W. Burdick	Rev.	Date	Sht.
E. Swartz	F	11/27/00	1 of 2

## Circuit Details, KAT2 Control Board

T1, D1, D2 (etc.) form a directional coupler for SWR and power measurements. This type of bridge is much more accurate than the K2's standard RF detector (D9) in the presence of non-50-ohm loads. The bridge output is buffered by op-amp U4 and routed to the K2 control board, overriding the signal from D9. The bridge outputs are also connected to A-to-D inputs on the microcontroller, U1. U1 measures these voltages and converts them to SWR or power readings, using averaging and linearization techniques to improve accuracy. The EEPROM (U2) stores network and SWR data for each band and antenna. K17 selects either a capacitor-in or capacitor-out network configuration, while K18 controls the antenna switch. U1 "sleeps" at all times except during actually antenna tune-up, so it generates no receiver noise.

### Control Board Schematic

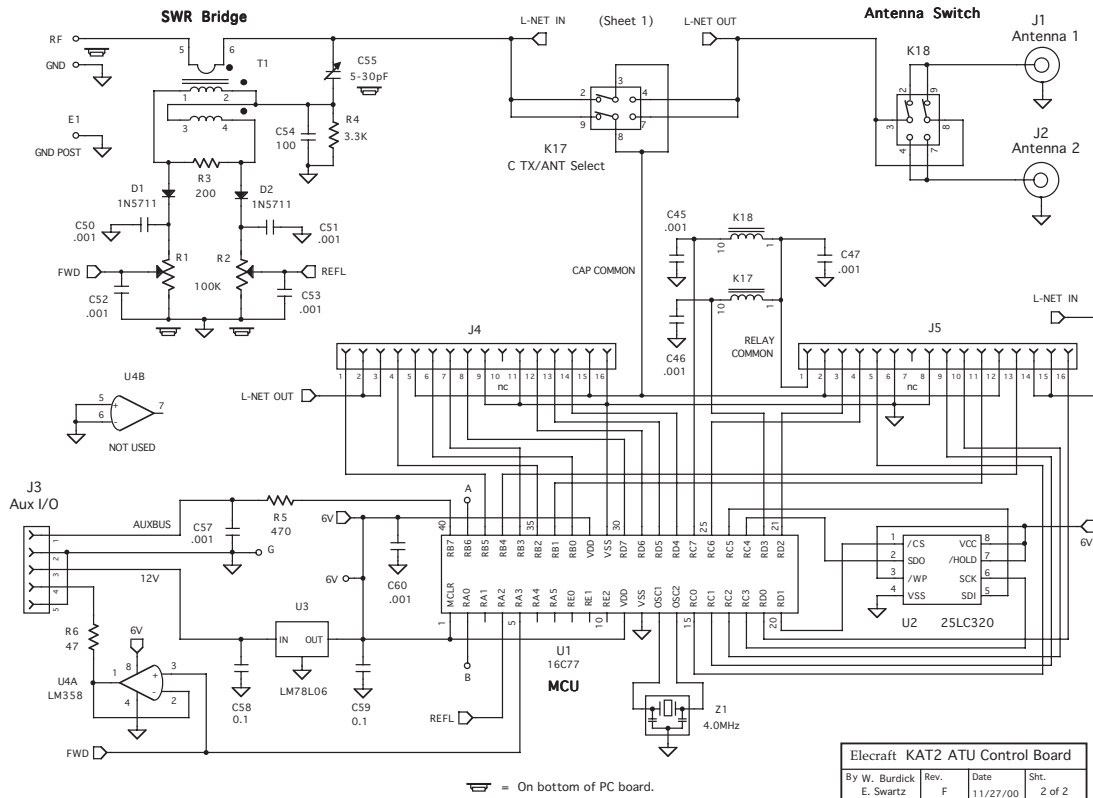

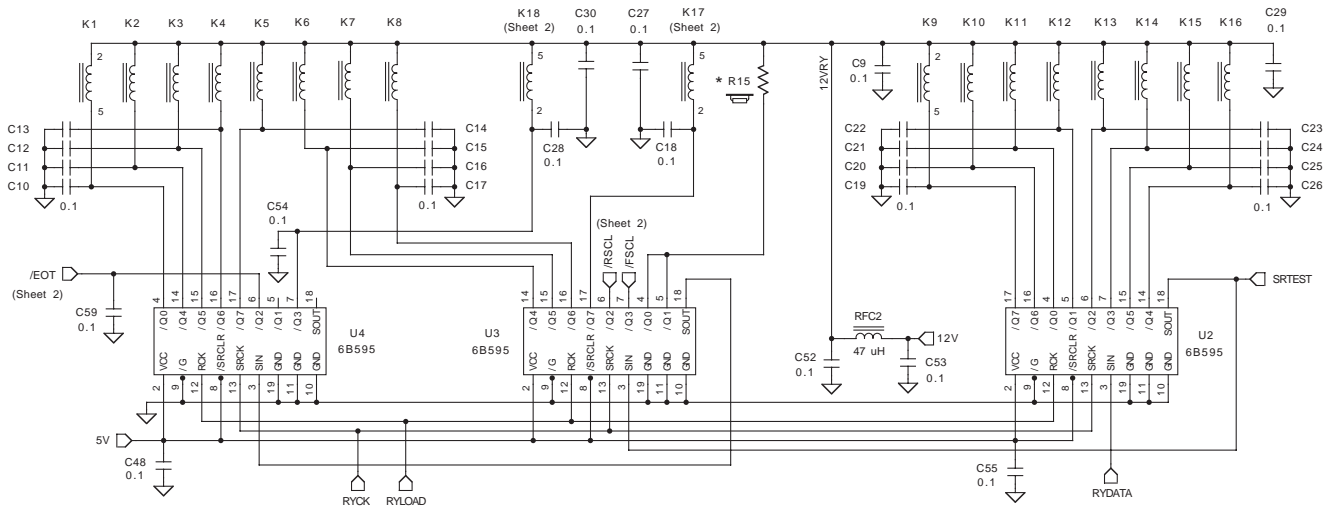
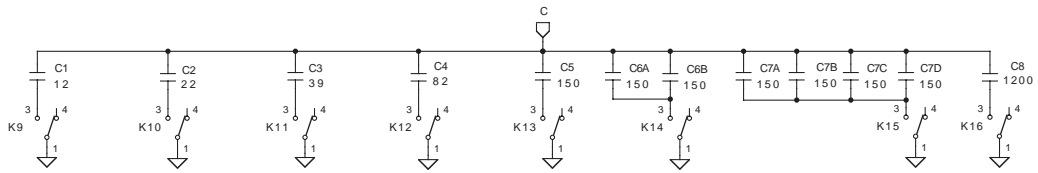
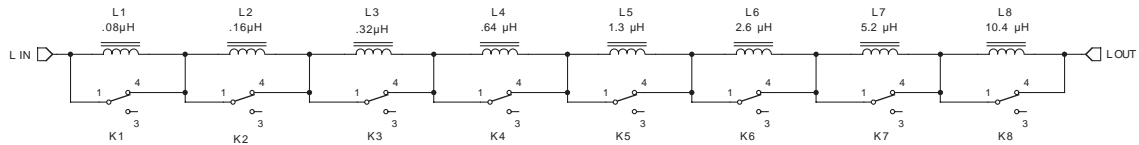

\* = Components not supplied; for future use.  
 = On bottom of PC board.  
 Note: All relays are shown in the N.C. position.

Elecrafft KAT100 RF Board			
By W. Burdick	Rev. B	Date 1/4/03	Sht. 1 of 2

Appendix A

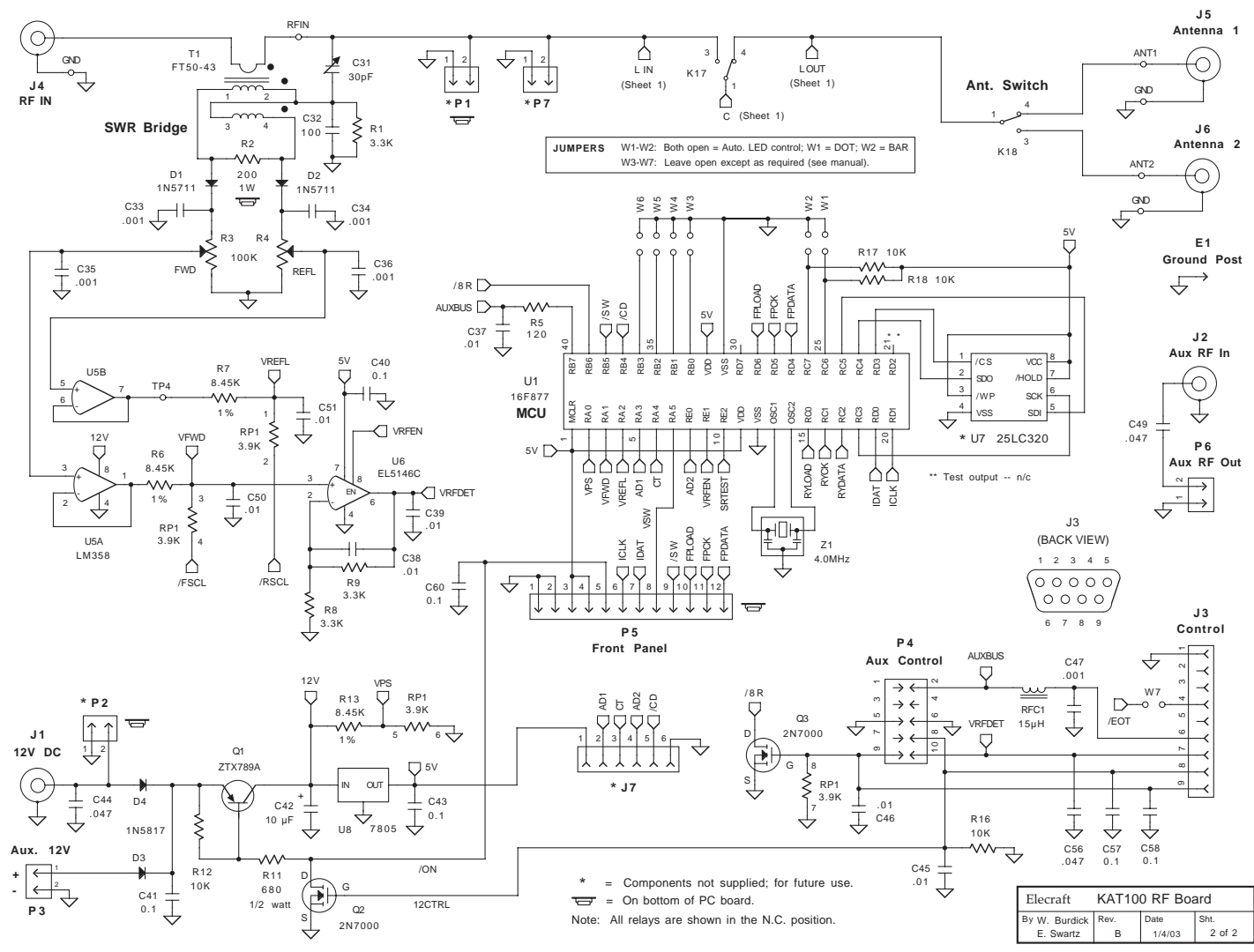

Appendix A



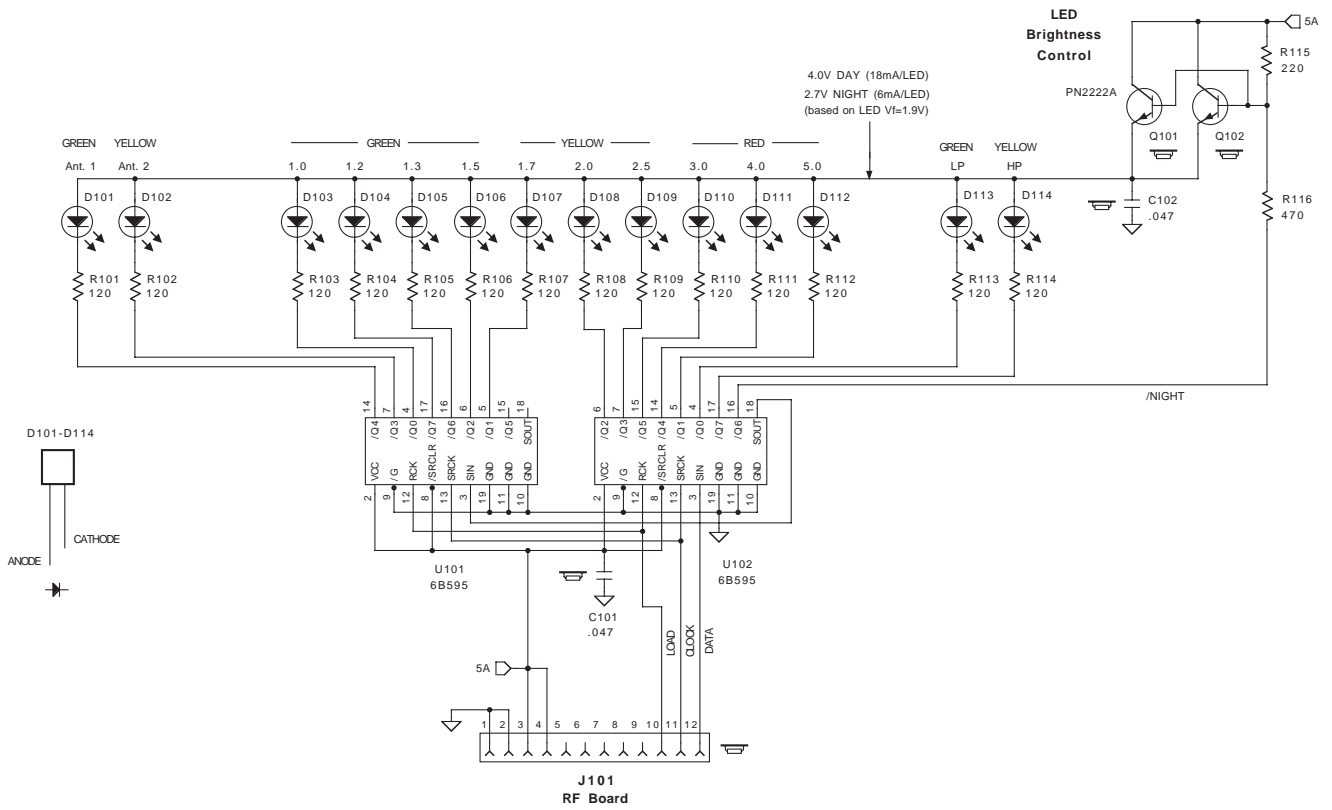

= On bottom of PC board.

Elecraft KAT100 Front Panel Board			
By W. Burdick E. Swartz	Rev. B	Date 1/4/03	Sht. 1 of 1

Appendix A

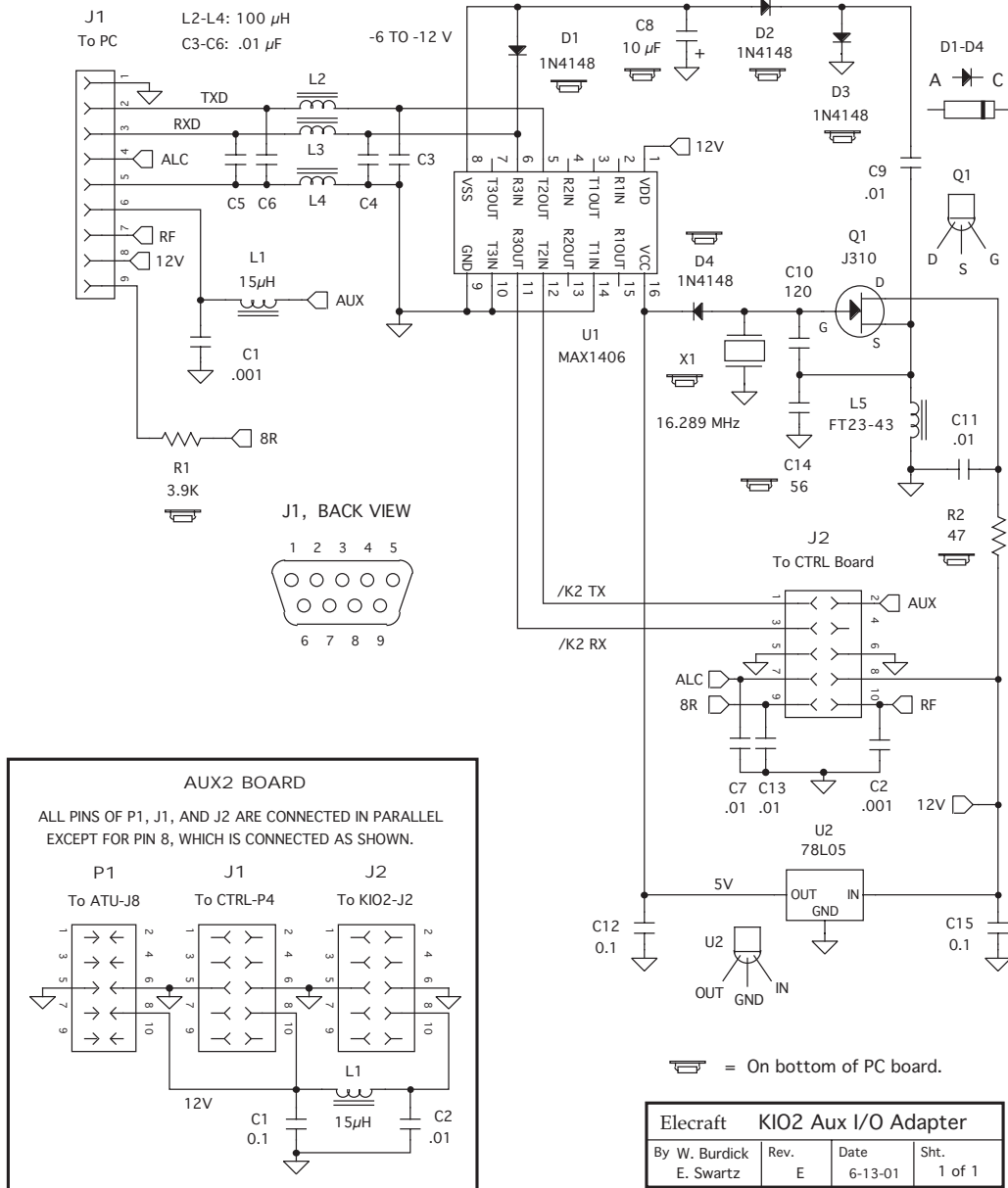

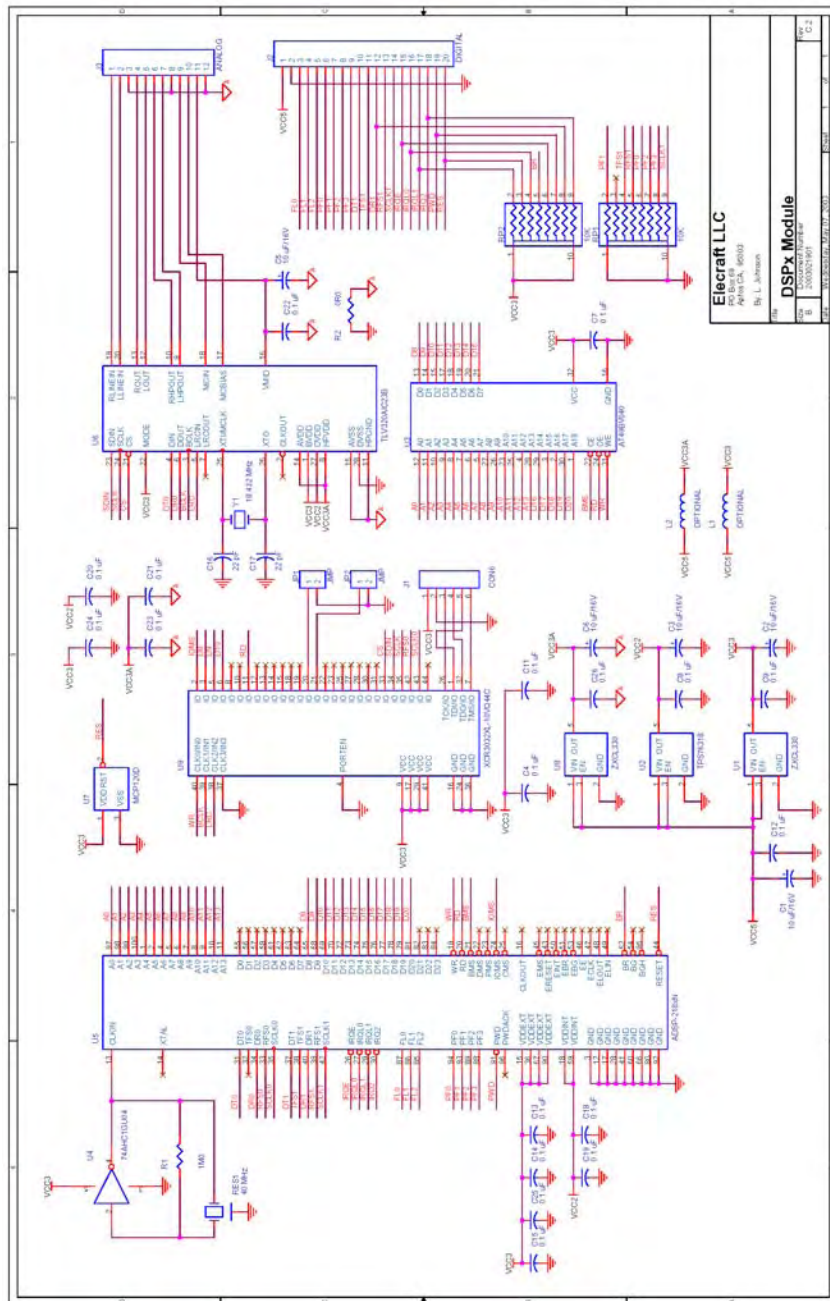

Electcraft LLC  
 PO Box 148  
 Ft. Lauderdale, FL 33301  
 954-575-1111  
 www.electcraft.com

DSPx Module  
 Rev. B  
 2002021901

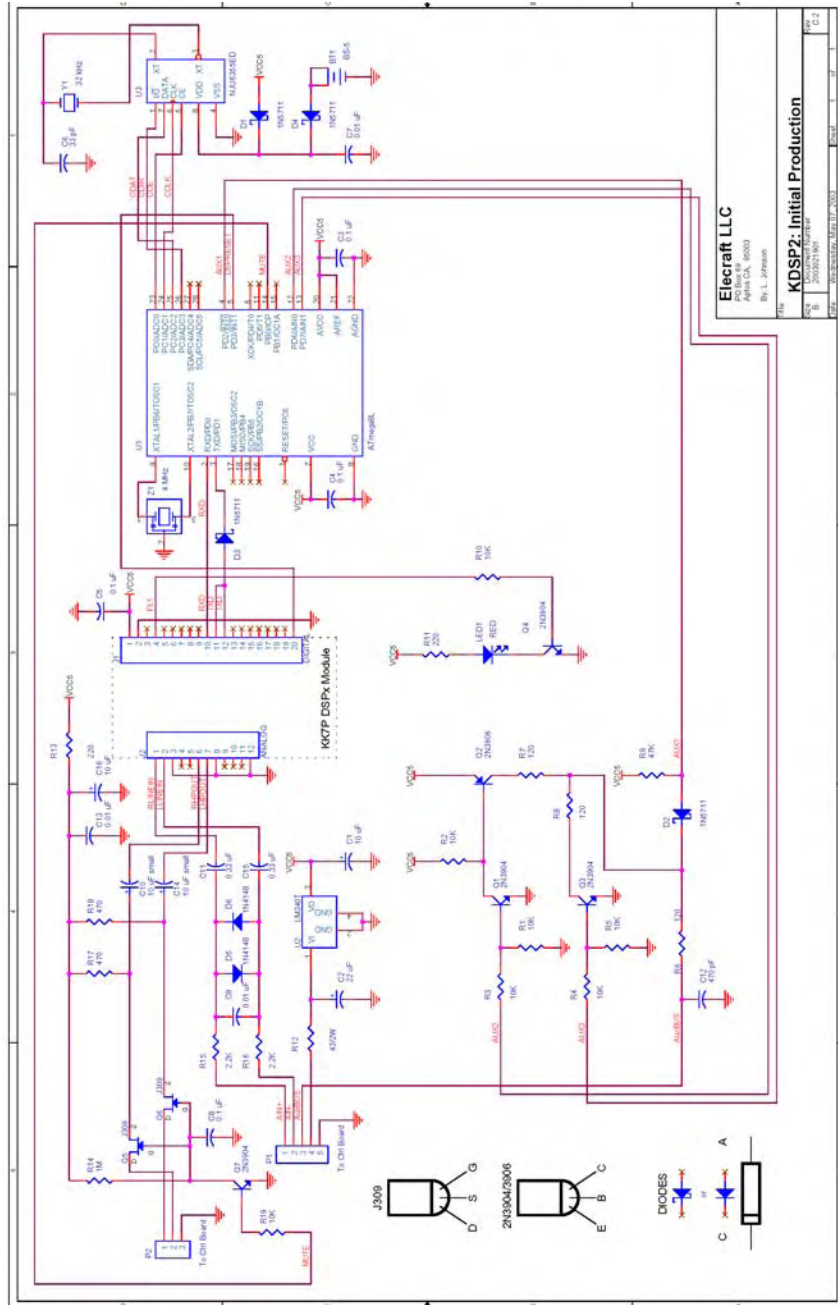

Elecraft LLC  
 PO Box 47  
 Agnes CA, 95920  
 By: L. Johnson

KDSP2: Initial Production  
 Rev: 1  
 Date: 2003/02/10  
 File: KDSP2\_0210\_01.PCB

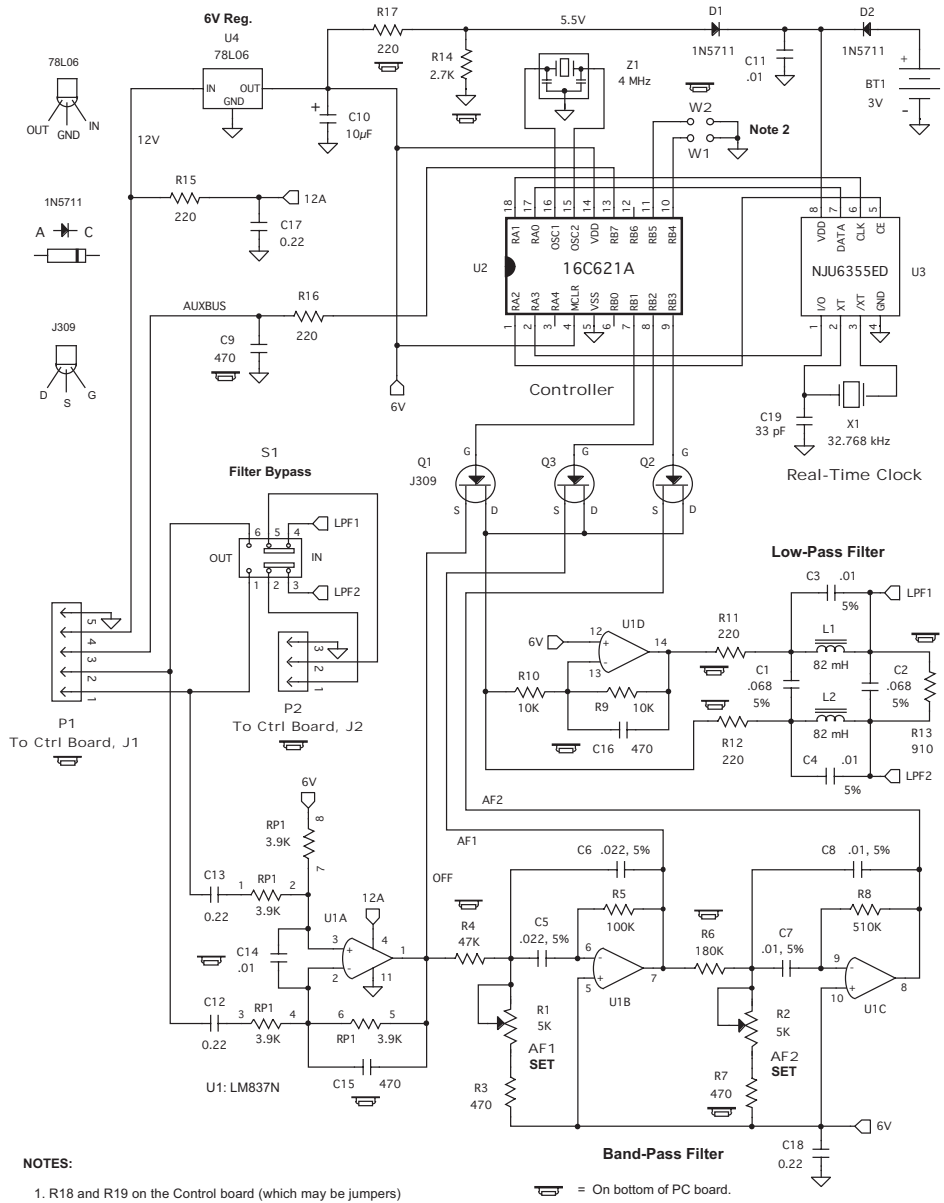

- NOTES:**
1. R18 and R19 on the Control board (which may be jumpers) must be removed when the KAF2 is installed.
  2. Install W1 to skip the first-stage band-pass filter output (AF1). Install W2 to select DD-MM-YY date format.

<b>Elecraft</b>		<b>KAF2 Audio Filter/RTC</b>	
By W. Burdick E. Swartz	Rev. A	Date 8-16-01	Sh. 1 of 1

# K60XV Schematic

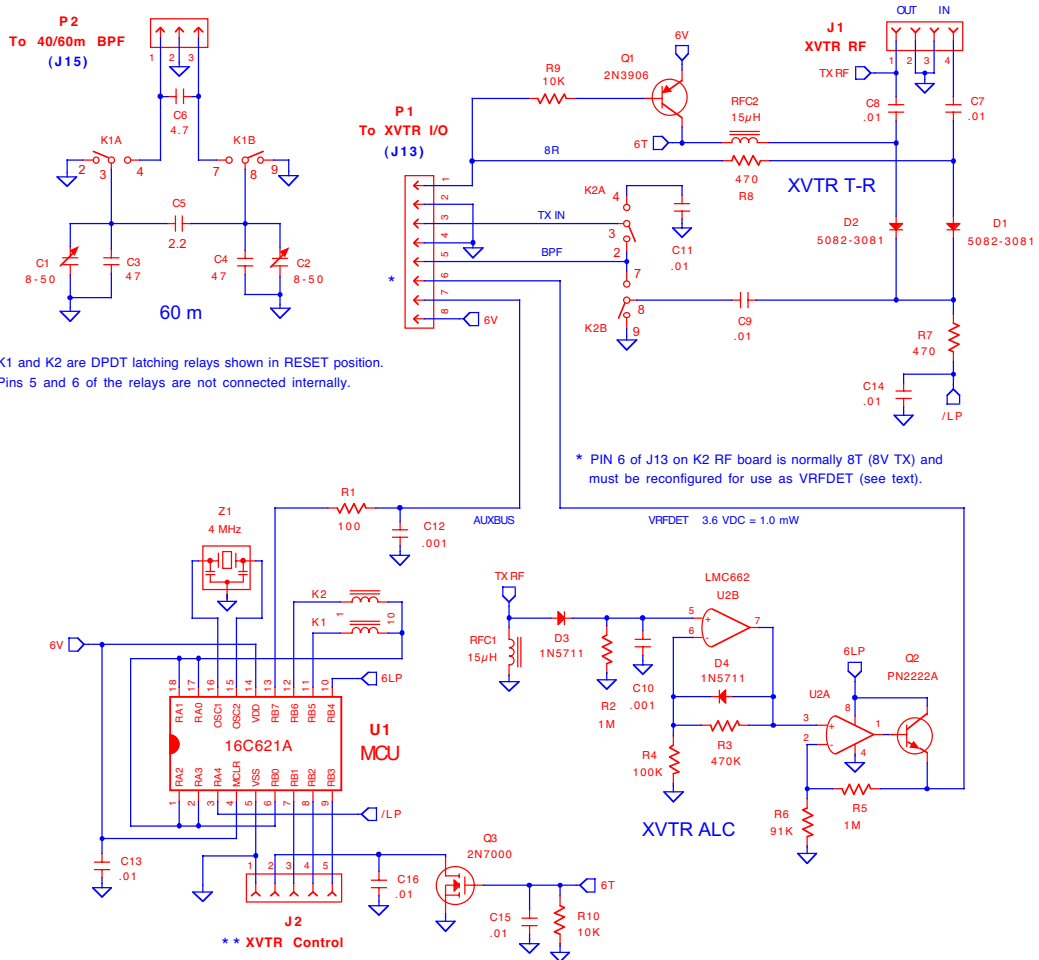

J2 PIN	FUNCTION
1	GROUND
2	XVTR KEYLINE
3	XVTR SELECT 0
4	XVTR SELECT 1
5	XVTR SELECT 2

} Binary encoding of ADR parameter in TRN menu entries (See text)

\*\* Not required with Elecraft XV Series Transverters.

Note: All components are located on the bottom of PC board except resistors, diodes, J1, and J2.

Elecraft K60XV 60m/XVTR IO			
By W. Burdick E. Swartz	Rev. B	Date 3/8/04	Sht. 1 of 1

# K60XV MANUAL ERRATA

Rev. A-3, June 8, 2004

**PLEASE MAKE THE FOLLOWING CHANGES TO THE MANUAL BEFORE PROCEEDING TO ENSURE THAT THE K60XV FUNCTIONS CORRECTLY**

**Page 13:** Delete the third assembly step from the bottom, which begins “Switch to 40 meters...”

**Page 16:** At the end of the first paragraph, add the sentence: “Leave **D19** set for **PA60=40**, even when using KPA100 kit revision C.” (See detailed information below.)

## IMPORTANT OPERATING NOTES:

**1. Using the KPA100 on 60 meters:** Recent KPA100 kit modifications (revision C) allow high-power operation on 60 meters. However, these changes **do not** include a revised 80-meter low-pass filter. For 60 meters, you’ll still use the KPA100’s 30/40-meter low-pass filter. For this reason, you must leave the K2’s **D19** menu parameter set for **PA60=40** (see K60XV manual).

**2. Using TUNE mode with the K60XV and KAT2 installed:** If the KAT2 is in either of its autotune modes (**AUTO** or **ALT**), and you’re on a transverter band configured for LP mode (Low Power, 0 dBm), holding TUNE drops power to 0.2 milliwatts maximum. You can override this behavior by holding **DISPLAY** along with TUNE, or by selecting any KAT2 mode other than **AUTO** or **ALT** in the menu.

**3. KAT2 modification for use with K60XV LP mode:** In some cases the LM358 op-amp on the KAT2 can load down the K60XV’s low-power RF detector (at the emitter of Q2), preventing the K60XV from developing a full 0 dBm (1 milliwatt) signal at the transverter OUT jack. To correct this, change R6 on the KAT2 from 47 ohms to 470 ohms. This resistor is supplied with the K60XV kit. R6 is on the bottom of the KAT2 control board, and can be changed without removing the KAT2 module.